

EMES Endüstriyel
Makina Ekipmanları

2018
FİYAT LİSTESİ
E k i m



EMES Endüstriyel
Makina Ekipmanları



HAKKIMIZDA

EMES A.Ş. 1998 yılında Türkiye ve Dünya pazarlarında ticaret yapan saygın kuruluşların işbirliği ile çok ortaklı bir şirket olarak kurulmuştur. Kısa bir süre içerisinde Türkiye ve Dünya pazarlarında güçlü bir marka olarak kendini kabul ettirmiştir. Kuruluşundan bugüne kadar geçen süre içerisinde ulaştığı yüksek kalite düzeyi ile iç ve dış pazarlarda rekabet edebilir hale gelmiştir. Vizyonunu sürekli kendini yenileyen dinamik yapısı ile ulusal ve küresel pazarlarda ilk ve en çok tercih edilen kaliteli ve güvenilir marka olarak belirleyen EMES A.Ş., Türkiye genelinde yaygın bayilik ağı ve yurtdışındaki geniş satış ağı ile başta Avrupa olmak üzere Ortadoğu, Afrika, Balkanlar ve Orta Asya'da yer alan 40'in üzerindeki ülkeye ihracat gerçekleştirmektedir.

EMES A.Ş. 8.000 m² lik kapalı alan üzerine kurulu modern tesislerinde eğitimli teknik kadrosu ile gerçekleştirdiği üretiminde, şirketin kalite politikasının da bir parçası haline gelen "mutlak müşteri memnuniyeti"ni hedefleyerek çalışmaktadır. Türkiye ve Dünya çapındaki kalitesi, dinamik ve yaratıcı personeli ile EMES A.Ş. kendine has bir insan kaynağı oluşturmuştur. Türkiye'de kendi sektöründe DIN EN ISO 9001:2008 belgesine sahip ilk firmadır. Misyonunu; sektörel gelişimleri yakından takip ederek bunları kalite politikasının birer parçası haline getirmek sürekli müşteri memnuniyetini hedefleyerek çalışanları ile birlikte daha güvenilir, kaliteli ve estetik tasarımlı ürünleri müşteriye sunmak olarak belirlemiştir. Türkiye'de ve Dünya'da yer alan müşterilerine bulunduğu sektöre özgü çözüm ve hizmetler sunmaktadır.

İÇİNDEKİLER

PAM 6-7	PAİM 8 STAINLESS STEEL INOX	PMA 9	KKA 10	İA 11 STAINLESS STEEL INOX	MAM 12
MAİM 13	MDA 14	MDA 14	MDAS 15	MDASç 15	MAS 16
DA 16	KT/KTs 17	PAS 18	PRAB 18	SA 19	SAİ 19 STAINLESS STEEL INOX
PAMB 20	KKAB 20	İAB 20 STAINLESS STEEL INOX	ÇDKK 21	KKÇK 21	DÇ 21
DK 22	PRd 23	PRk 23	PRA 24	PPA 24	PDKK 25
PDK 25	PÇ 25	PKBİ 26 STAINLESS STEEL INOX	PKCi 26 STAINLESS STEEL INOX	PKB 27	PKC 27
PKBİt 28 STAINLESS STEEL INOX	PKCiT 28 STAINLESS STEEL INOX	PKBt 29	PKCt 29	ZKC 30	ZKB 30
ZKct 31	ZKBt 31	PT 32	PTt 32	PTk 32	PYB 33

İÇİNDEKİLER

PYC 33	PYBt 34	PYCt 34	PYBk 35	PYCK 35	PYBP 36
PYCP 36	PYBPt 37	PYCPt 37	PYBPK 38	PYCPK 38	PTB6 39
PTC6 39	PTB4 40	PTC4 40	BKB/BKC 41	BYB/BYC 42	BTB/BSDC 43
BSB/BSC 44	BTVB/ BTVC 45	BTV/BTVBb 46	BDV 46	BKV 47	BT 47
AT 47	MTs 48	MTk 48	PM 49	ZMb 49	ZMk 49
ZMCK 50	PMC 50	ZMcb 50	SMb 50	YPKk 51	YPKb 51
YPKp 51	YPK2 52	YPK3 52	YPK4 52	ANAHTAR 52	TCBp 53
TCCp 54	TBBp 55	TCp 56	TBp 57	TKCP 58	TMCp 58

PAM PLASTİK AYAK MAFSALLI

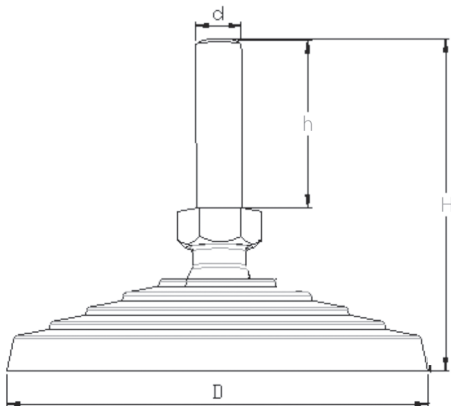

YENİ ÜRÜN

Ürün kodu	D	d	h	H	Sw	Kg	Pkt	Fiyat
PAM 40 08 45	40	M8	45	74	13	400	25	5,39 TL
PAM 40 08 60	40	M8	60	89	13	400	25	5,78 TL
PAM 40 10 45	40	M10	45	74	13	400	25	5,78 TL
PAM 40 10 50	40	M10	50	79	13	400	25	5,86 TL
PAM 40 10 60	40	M10	60	89	13	400	25	6,13 TL
PAM 40 10 75	40	M10	75	104	13	400	25	6,48 TL
PAM 40 10 90	40	M10	90	119	13	400	25	6,83 TL
PAM 40 10 10	40	M10	100	129	13	400	25	7,18 TL
PAM 40 10 12	40	M10	120	149	13	400	25	7,35 TL
PAM 40 12 45	40	M12	45	74	13	400	25	6,65 TL
PAM 40 12 50	40	M12	50	79	13	400	25	6,74 TL
PAM 40 12 60	40	M12	60	89	13	400	25	7,00 TL
PAM 40 12 75	40	M12	75	104	13	400	25	7,35 TL
PAM 40 12 90	40	M12	90	119	13	400	25	7,70 TL
PAM 40 12 10	40	M12	100	129	13	400	25	8,75 TL
PAM 40 12 12	40	M12	120	149	13	400	25	10,50 TL
PAM 50 08 45	50	M8	45	74	13	450	25	5,78 TL
PAM 50 08 60	50	M8	60	89	13	450	25	6,13 TL
PAM 50 10 45	50	M10	45	74	13	450	25	6,13 TL
PAM 50 10 50	50	M10	50	79	13	450	25	6,21 TL
PAM 50 10 60	50	M10	60	89	13	450	25	6,48 TL
PAM 50 10 75	50	M10	75	104	13	450	25	6,83 TL
PAM 50 10 90	50	M10	90	119	13	450	25	7,18 TL
PAM 50 10 10	50	M10	100	129	13	450	25	7,53 TL
PAM 50 10 12	50	M10	120	149	13	450	25	7,70 TL
PAM 50 12 45	50	M12	45	74	13	450	25	7,00 TL
PAM 50 12 50	50	M12	50	79	13	450	25	7,09 TL
PAM 50 12 60	50	M12	60	89	13	450	25	7,35 TL
PAM 50 12 75	50	M12	75	104	13	450	25	7,70 TL
PAM 50 12 90	50	M12	90	119	13	450	25	8,05 TL
PAM 50 12 10	50	M12	100	129	13	450	25	9,10 TL
PAM 50 12 12	50	M12	120	149	13	450	25	10,85 TL
PAM 60 08 45	60	M8	45	76	13	500	10	6,42 TL
PAM 60 08 60	60	M8	60	91	13	500	10	7,00 TL
PAM 60 10 45	60	M10	45	76	13	500	10	7,15 TL
PAM 60 10 50	60	M10	50	81	13	500	10	7,15 TL
PAM 60 10 60	60	M10	60	91	13	500	10	7,29 TL
PAM 60 10 75	60	M10	75	106	13	500	10	7,58 TL
PAM 60 10 90	60	M10	90	121	13	500	10	8,02 TL
PAM 60 10 10	60	M10	100	131	13	500	10	8,17 TL
PAM 60 10 12	60	M12	120	151	13	500	10	8,60 TL

PAM PLASTİK AYAK MAFSALLI



Ürün kodu	D	d	h	H	Sw	Kg	Pkt	Fiyat
PAM 60 12 60	60	M12	60	91	19	500	16	14,35 TL
PAM 60 12 10	60	M12	100	131	19	500	16	14,70 TL
PAM 60 12 15	60	M12	150	181	19	500	16	20,65 TL
PAM 60 16 60	60	M16	60	91	19	500	16	12,95 TL
PAM 60 16 10	60	M16	100	131	19	500	16	14,70 TL
PAM 60 16 15	60	M16	150	181	19	500	16	22,05 TL
PAM 60 16 20	60	M16	200	231	22	500	16	27,56 TL
PAM 60 20 10	60	M20	100	131	22	500	16	22,05 TL
PAM 60 20 15	60	M20	150	181	22	500	16	26,60 TL
PAM 60 20 20	60	M20	200	231	22	500	16	33,08 TL
PAM 80 12 60	80	M12	60	91	19	600	16	16,10 TL
PAM 80 12 10	80	M12	100	131	19	600	16	16,45 TL
PAM 80 12 15	80	M12	150	181	19	600	16	22,40 TL
PAM 80 16 60	80	M16	60	91	19	600	16	14,70 TL
PAM 80 16 10	80	M16	100	131	19	600	16	16,45 TL
PAM 80 16 15	80	M16	150	181	19	600	16	23,80 TL
PAM 80 16 20	80	M16	200	231	22	600	16	29,31 TL
PAM 80 20 10	80	M20	100	131	22	600	16	23,80 TL
PAM 80 20 15	80	M20	150	181	22	600	16	28,35 TL
PAM 80 20 20	80	M20	200	231	22	600	16	34,83 TL
PAM 11 12 60	110	M12	60	91	19	1000	16	17,85 TL
PAM 11 12 10	110	M12	100	131	19	1000	16	18,20 TL
PAM 11 12 15	110	M12	150	181	19	1000	16	24,15 TL
PAM 11 16 60	110	M16	60	91	19	1000	16	16,45 TL
PAM 11 16 10	110	M16	100	131	19	1000	16	18,20 TL
PAM 11 16 15	110	M16	150	181	19	1000	16	25,55 TL
PAM 11 16 20	110	M16	200	231	22	1000	16	31,06 TL
PAM 11 20 10	110	M20	100	131	22	1000	16	25,55 TL
PAM 11 20 15	110	M20	150	181	22	1000	16	30,10 TL
PAM 11 20 20	110	M20	200	231	22	1000	16	36,58 TL

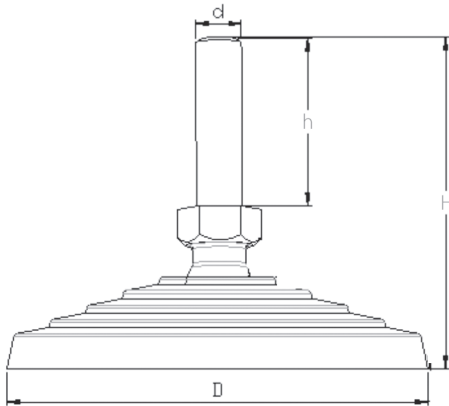

PAİM PLASTİK AYAK İNOX MAFSALLI



Ürün kodu	D	d	h	H	Sw	Kg	Pkt	Fiyat
PAİM 40 08 60	40	M8	60	89	13	400	16	19,25 TL
PAİM 40 10 50	40	M10	50	79	13	400	16	19,25 TL
PAİM 40 10 75	40	M10	75	104	13	400	16	20,13 TL
PAİM 40 10 10	40	M10	100	129	13	400	16	21,00 TL
PAİM 40 12 50	40	M12	50	79	13	400	16	21,00 TL
PAİM 40 12 75	40	M12	75	104	13	400	16	21,88 TL
PAİM 40 12 10	40	M12	100	129	13	400	16	22,75 TL
PAİM 50 08 60	50	M8	60	89	13	450	16	20,13 TL
PAİM 50 10 50	50	M10	50	79	13	450	16	20,13 TL
PAİM 50 10 75	50	M10	75	104	13	450	16	21,00 TL
PAİM 50 10 10	50	M10	100	129	13	450	16	21,88 TL
PAİM 50 12 50	50	M12	50	79	13	450	16	21,88 TL
PAİM 50 12 75	50	M12	75	104	13	450	16	22,75 TL
PAİM 50 12 10	50	M12	100	129	13	450	16	23,63 TL
PAİM 60 16 10	60	M16	100	131	19	500	16	57,75 TL
PAİM 60 16 15	60	M16	150	181	19	500	16	77,00 TL
PAİM 60 20 10	60	M20	100	131	22	500	16	94,50 TL
PAİM 60 20 15	60	M20	150	181	22	500	16	112,00 TL
PAİM 80 16 10	80	M16	100	131	19	600	16	61,25 TL
PAİM 80 16 15	80	M16	150	181	19	600	16	82,25 TL
PAİM 80 20 10	80	M20	100	131	22	600	16	99,75 TL
PAİM 80 20 15	80	M20	150	181	22	600	16	117,25 TL
PAİM 11 16 10	110	M16	100	131	19	1000	16	73,50 TL
PAİM 11 16 15	110	M16	150	181	19	1000	16	85,75 TL
PAİM 11 20 10	110	M20	100	131	22	1000	16	103,25 TL
PAİM 11 20 15	110	M20	150	181	22	1000	16	120,75 TL

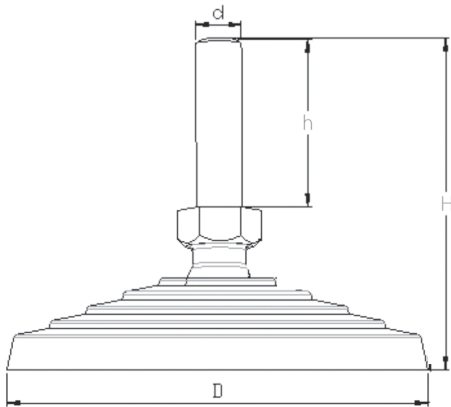

PMA PLASTİK MAFSALLI AYAK

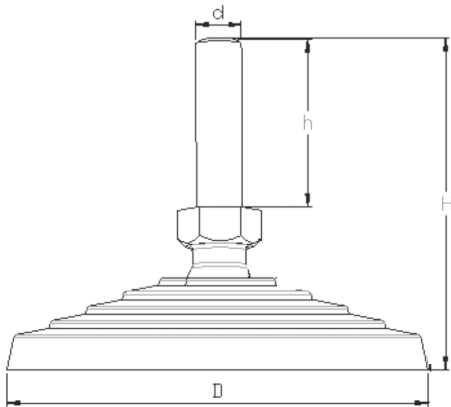

Ürün kodu	D	d	h	H	Sw	Pkt	Fiyat
PMA 60 10 50	60	M10	50	94	24	16	5,43 TL
PMA 60 10 10	60	M10	100	144	24	16	6,48 TL
PMA 60 12 50	60	M12	50	94	24	16	5,78 TL
PMA 60 12 10	60	M12	100	144	24	16	7,53 TL
PMA 60 16 50	60	M16	50	94	24	16	13,30 TL
PMA 60 16 10	60	M16	100	144	24	16	15,75 TL
PMA 60 16 15	60	M16	150	194	24	16	17,50 TL
PMA 60 16 20	60	M16	200	244	24	16	19,25 TL
PMA 60 20 50	60	M20	50	94	24	16	15,75 TL
PMA 60 20 10	60	M20	100	144	24	16	17,50 TL
PMA 60 20 15	60	M20	150	194	24	16	21,00 TL
PMA 60 20 20	60	M20	200	244	24	16	24,50 TL
PMA 80 10 50	80	M10	50	94	24	16	6,30 TL
PMA 80 10 10	80	M10	100	144	24	16	7,35 TL
PMA 80 12 50	80	M12	50	94	24	16	6,65 TL
PMA 80 12 10	80	M12	100	144	24	16	8,40 TL
PMA 80 16 50	80	M16	50	94	24	16	14,18 TL
PMA 80 16 10	80	M16	100	144	24	16	16,63 TL
PMA 80 16 15	80	M16	150	194	24	16	18,38 TL
PMA 80 16 20	80	M16	200	244	24	16	20,13 TL
PMA 80 20 50	80	M20	50	94	24	16	16,63 TL
PMA 80 20 10	80	M20	100	144	24	16	18,38 TL
PMA 80 20 15	80	M20	150	194	24	16	21,88 TL
PMA 80 20 20	80	M20	200	244	24	16	25,38 TL
PMA 11 10 50	110	M10	50	94	24	16	8,05 TL
PMA 11 10 10	110	M10	100	144	24	16	9,10 TL
PMA 11 12 50	110	M12	50	94	24	16	8,40 TL
PMA 11 12 10	110	M12	100	144	24	16	10,15 TL
PMA 11 16 50	110	M16	50	94	24	16	15,93 TL
PMA 11 16 10	110	M16	100	144	24	16	18,38 TL
PMA 11 16 15	110	M16	150	194	24	16	20,13 TL
PMA 11 16 20	110	M16	200	244	24	16	21,88 TL
PMA 11 20 50	110	M20	50	94	24	16	18,38 TL
PMA 11 20 10	110	M20	100	144	24	16	20,13 TL
PMA 11 20 15	110	M20	150	194	24	16	23,63 TL
PMA 11 20 20	110	M20	200	244	24	16	27,13 TL

KKA KROM KAPLI AYAK

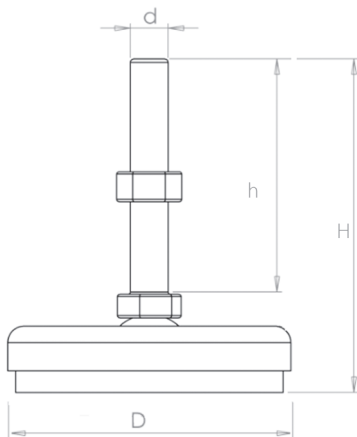

Ürün kodu	D	d	h	H	Sw	Kg	Pkt	Fiyat
KKA 40 08 50	40	M8	50	71	13	200	10	17,50 TL
KKA 40 08 90	40	M8	90	111	13	200	10	18,96 TL
KKA 40 10 50	40	M10	50	71	13	200	10	17,79 TL
KKA 40 10 70	40	M10	70	91	13	200	10	19,54 TL
KKA 40 10 10	40	M10	100	121	13	200	10	21,29 TL
KKA 40 10 15	40	M10	150	171	13	200	10	22,17 TL
KKA 40 12 50	40	M12	50	71	13	200	10	22,17 TL
KKA 40 12 70	40	M12	70	91	13	200	10	23,04 TL
KKA 40 12 10	40	M12	100	121	13	200	10	24,79 TL
KKA 60 08 50	60	M8	50	71	13	250	10	18,96 TL
KKA 60 08 90	60	M8	90	111	13	250	10	20,42 TL
KKA 60 10 50	60	M10	50	83	13	250	10	19,25 TL
KKA 60 10 70	60	M10	70	103	13	250	10	21,00 TL
KKA 60 10 10	60	M10	100	133	13	250	10	22,75 TL
KKA 60 10 15	60	M10	150	183	13	250	10	23,63 TL
KKA 60 12 50	60	M12	50	83	17	300	10	23,63 TL
KKA 60 12 70	60	M12	70	103	17	300	10	22,75 TL
KKA 60 12 10	60	M12	100	133	17	300	10	26,25 TL
KKA 60 12 15	60	M12	150	183	17	300	10	28,00 TL
KKA 60 16 10	60	M16	100	133	19	400	10	28,00 TL
KKA 80 12 70	80	M12	70	116	17	400	10	33,25 TL
KKA 80 12 10	80	M12	100	146	17	400	10	35,00 TL
KKA 80 12 15	80	M12	150	196	17	400	10	36,75 TL
KKA 80 16 10	80	M16	100	146	19	500	10	36,75 TL
KKA 80 16 15	80	M16	150	196	19	500	10	38,50 TL
KKA 80 20 10	80	M20	100	146	22	600	10	43,75 TL
KKA 80 20 15	80	M20	150	196	22	600	10	52,50 TL
KKA 10 12 70	100	M12	70	116	17	350	8	38,50 TL
KKA 10 12 10	100	M12	100	146	17	350	8	40,25 TL
KKA 10 12 15	100	M12	150	196	19	350	8	42,00 TL
KKA 10 16 10	100	M16	100	146	19	600	8	43,75 TL
KKA 10 16 15	100	M16	150	196	19	600	8	45,50 TL
KKA 10 20 10	100	M20	100	146	22	800	8	52,50 TL
KKA 10 20 15	100	M20	150	196	22	800	8	61,25 TL
KKA 12 12 70	120	M12	70	120	17	600	4	45,50 TL
KKA 12 12 10	120	M12	100	150	17	600	4	47,25 TL
KKA 12 12 15	120	M12	150	200	17	600	4	49,00 TL
KKA 12 16 10	120	M16	100	150	19	800	4	50,75 TL
KKA 12 16 15	120	M16	150	200	19	800	4	52,50 TL
KKA 12 20 10	120	M20	100	150	22	1000	4	61,25 TL
KKA 12 20 15	120	M20	150	200	22	1000	4	70,00 TL
KKA 16 16 10	160	M16	100	164	19	1200	1	115,50 TL
KKA 16 16 15	160	M16	150	214	22	1200	1	119,00 TL
KKA 16 20 10	160	M20	100	164	22	1200	1	119,00 TL
KKA 16 20 15	160	M20	150	214	22	1200	1	140,00 TL

İA INOX AYAK



YENİ
ÜRÜN

Ürün kodu	D	d	h	H	Sw	Kg	Pkt	Fiyat
İA 40 10 70	40	M10	70	91	13	200	10	26,54 TL
İA 40 10 10	40	M10	100	121	13	200	10	28,29 TL
İA 40 10 15	40	M10	150	171	13	200	10	35,29 TL
İA 40 12 70	40	M12	70	91	13	200	10	37,04 TL
İA 40 12 10	40	M12	100	121	13	200	10	38,79 TL
İA 40 12 15	40	M12	150	171	13	200	10	40,54 TL
İA 40 16 10	40	M16	100	121	13	200	10	47,54 TL
İA 60 10 70	60	M10	70	103	13	250	10	28,00 TL
İA 60 10 10	60	M10	100	133	13	250	10	29,75 TL
İA 60 10 15	60	M10	150	183	13	250	10	36,75 TL
İA 60 12 70	60	M12	70	103	17	300	10	38,50 TL
İA 60 12 10	60	M12	100	133	17	300	10	40,25 TL
İA 60 12 15	60	M12	150	183	17	300	10	42,00 TL
İA 60 16 10	60	M16	100	133	19	400	10	45,50 TL
İA 80 12 70	80	M12	70	116	17	400	10	52,50 TL
İA 80 12 10	80	M12	100	146	17	400	10	54,25 TL
İA 80 12 15	80	M12	150	196	17	400	10	56,00 TL
İA 80 16 10	80	M16	100	146	19	500	10	63,00 TL
İA 80 16 15	80	M16	150	196	19	500	10	77,00 TL
İA 80 20 10	80	M20	100	146	22	600	10	71,75 TL
İA 80 20 15	80	M20	150	196	22	600	10	112,00 TL
İA 10 12 70	100	M12	70	116	17	350	8	54,25 TL
İA 10 12 10	100	M12	100	146	17	350	8	56,00 TL
İA 10 12 15	100	M12	150	196	17	350	8	64,75 TL
İA 10 16 10	100	M16	100	146	19	600	8	71,75 TL
İA 10 16 15	100	M16	150	196	19	600	8	84,00 TL
İA 10 20 10	100	M20	100	146	22	800	8	84,00 TL
İA 10 20 15	100	M20	150	196	22	800	8	119,00 TL
İA 12 12 70	120	M12	70	116	17	600	4	70,00 TL
İA 12 12 10	120	M12	100	146	17	600	4	87,50 TL
İA 12 12 15	120	M12	150	196	17	600	4	84,00 TL
İA 12 16 10	120	M16	100	146	19	800	4	94,50 TL
İA 12 16 15	120	M16	150	196	19	800	4	105,00 TL
İA 12 20 10	120	M20	100	146	22	1000	4	105,00 TL
İA 12 20 15	120	M20	150	196	22	1000	4	140,00 TL
İA 16 16 10	160	M16	100	164	19	1200	1	206,50 TL
İA 16 16 15	160	M16	150	214	19	1200	1	213,50 TL
İA 16 20 10	160	M20	100	164	22	1200	1	213,50 TL
İA 16 20 15	160	M20	150	214	22	1200	1	238,00 TL

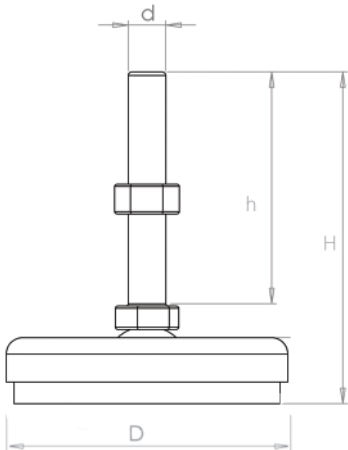

MAM METAL AYAK MAFSALLI

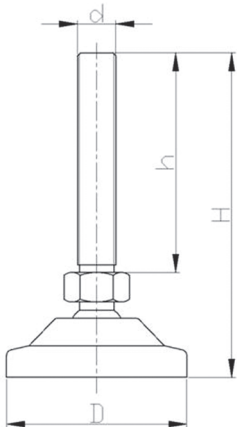

Ürün kodu	D	d	h	H	Sw	Kg	Pkt	Fiyat
MAM 60 10 45	60	M10	45	78	13	450	4	34,91 TL
MAM 60 10 50	60	M10	50	83	13	450	4	35,04 TL
MAM 60 10 60	60	M10	60	93	13	450	4	35,28 TL
MAM 60 10 75	60	M10	75	108	13	450	4	35,65 TL
MAM 60 10 90	60	M10	90	123	13	450	4	36,02 TL
MAM 60 10 10	60	M10	100	133	13	450	4	36,26 TL
MAM 60 10 12	60	M10	120	153	13	450	4	36,75 TL
MAM 60 12 45	60	M12	45	78	13	450	4	36,14 TL
MAM 60 12 50	60	M12	50	83	13	450	4	36,26 TL
MAM 60 12 60	60	M12	60	93	13	450	4	36,51 TL
MAM 60 12 75	60	M12	75	108	13	450	4	36,87 TL
MAM 60 12 90	60	M12	90	123	13	450	4	37,24 TL
MAM 60 12 10	60	M12	100	133	13	450	4	37,49 TL
MAM 60 12 12	60	M12	120	153	13	450	4	37,98 TL
MAM 60 16 60	60	M16	60	95	19	500	4	46,55 TL
MAM 60 16 10	60	M16	100	135	19	500	4	51,21 TL
MAM 60 16 15	60	M16	150	185	19	500	4	55,86 TL
MAM 60 16 20	60	M16	200	235	19	500	4	60,52 TL
MAM 60 20 10	60	M20	100	135	22	500	4	55,86 TL
MAM 60 20 15	60	M20	150	185	22	500	4	60,52 TL
MAM 60 20 20	60	M20	200	235	22	500	4	65,17 TL
MAM 80 16 60	80	M16	60	95	19	600	4	65,17 TL
MAM 80 16 10	80	M16	100	135	19	600	4	69,83 TL
MAM 80 16 15	80	M16	150	185	19	600	4	74,48 TL
MAM 80 16 20	80	M16	200	235	19	600	4	79,14 TL
MAM 80 20 10	80	M20	100	135	22	600	4	74,48 TL
MAM 80 20 15	80	M20	150	185	19	600	4	79,14 TL
MAM 80 20 20	80	M20	200	235	22	600	4	83,79 TL
MAM 10 16 60	100	M16	60	95	19	600	4	83,79 TL
MAM 10 16 10	100	M16	100	135	19	600	4	88,45 TL
MAM 10 16 15	100	M16	150	185	19	600	4	93,10 TL
MAM 10 16 20	100	M16	200	235	22	600	4	97,76 TL
MAM 10 20 10	100	M20	100	135	22	600	4	93,10 TL
MAM 10 20 15	100	M20	150	185	22	600	4	97,76 TL
MAM 10 20 20	100	M20	200	235	22	600	4	102,41 TL

MAİM METAL AYAK İNOX MAFSALLI



YENİ
ÜRÜN

Ürün kodu	D	d	h	H	Sw	Kg	Pkt	Fiyat
MAİM 60 10 50	60	M10	50	83	13	900	4	119,58 TL
MAİM 60 10 75	60	M10	75	108	13	900	4	120,31 TL
MAİM 60 10 100	60	M10	100	133	13	900	4	121,92 TL
MAİM 60 12 50	60	M12	50	83	13	900	4	119,58 TL
MAİM 60 12 75	60	M12	75	108	13	900	4	122,50 TL
MAİM 60 12 100	60	M12	100	133	13	900	4	125,42 TL
MAİM 60 16 100	60	M16	100	135	19	1000	4	157,50 TL
MAİM 60 16 150	60	M16	150	185	19	1000	4	167,13 TL
MAİM 60 16 200	60	M16	200	235	19	1000	4	180,83 TL
MAİM 60 20 100	60	M20	100	135	22	1000	4	198,33 TL
MAİM 60 20 150	60	M20	150	185	22	1000	4	221,67 TL
MAİM 60 20 200	60	M20	200	235	22	1000	4	245,00 TL
MAİM 80 16 100	80	M16	100	135	19	1200	4	180,83 TL
MAİM 80 16 150	80	M16	150	185	19	1200	4	190,46 TL
MAİM 80 16 200	80	M16	200	235	19	1200	4	204,17 TL
MAİM 80 20 100	80	M20	100	135	22	1200	4	221,67 TL
MAİM 80 20 150	80	M20	150	185	19	1200	4	245,00 TL
MAİM 80 20 200	80	M20	200	235	22	1200	4	268,33 TL
MAİM 100 16 100	100	M16	100	135	19	1500	4	221,67 TL
MAİM 100 16 150	100	M16	150	185	19	1500	4	231,29 TL
MAİM 100 16 200	100	M16	200	235	22	1500	4	245,00 TL
MAİM 100 20 100	100	M20	100	135	22	1500	4	262,50 TL
MAİM 100 20 150	100	M20	150	185	22	1500	4	285,83 TL
MAİM 100 20 200	100	M20	200	235	22	1500	4	309,17 TL

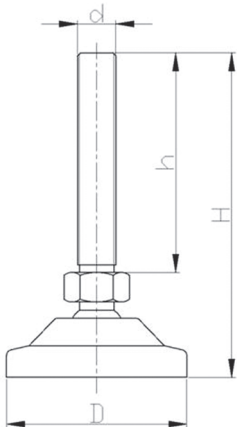

MDA MAKİNE DENGE AYAĞI

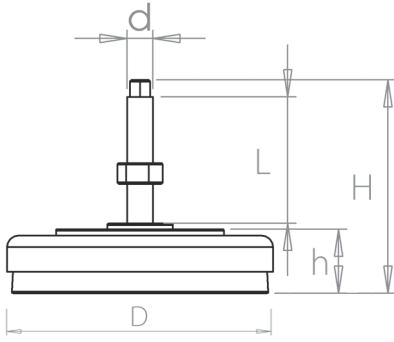

Diş Ölçüleri

A: 1,25 B: 1,50 C: 1,75 D: 2,00 E: 2,50 F: 3,00 G: 3,50

Ürün kodu	D	d	L	H	Kg	Ayr/msf	Pkt	Fiyat
MDA 80 10 10 B	80	M10x1,5	100	145	500	12	4	52,50 TL
MDA 80 12 12 A	80	M12x1,25	120	165	500	12	4	54,25 TL
MDA 80 16 12 B	80	M16x1,5	120	165	500	12	4	57,75 TL
MDA 80 16 12 D	80	M16x2	120	165	500	12	4	57,75 TL
MDA 12 10 10 B	120	M10x1,5	100	145	1000	12	1	75,25 TL
MDA 12 12 12 A	120	M12x1,25	120	165	1000	12	1	77,00 TL
MDA 12 16 12 B	120	M16x1,5	120	165	1000	12	1	80,50 TL
MDA 12 16 12 D	120	M16x2	120	165	1000	12	1	80,50 TL
MDA 16 16 12 B	160	M16x1,5	120	175	2000	15	1	108,50 TL
MDA 16 16 12 D	160	M16x2	120	175	2000	15	1	108,50 TL
MDA 16 20 17 B	160	M20x1,5	170	225	2000	15	1	117,25 TL
MDA 16 20 17 E	160	M20x2,5	170	225	2000	15	1	117,25 TL
MDA 20 20 17 B	200	M20x1,5	170	225	5000	25	1	201,25 TL
MDA 20 20 17 E	200	M20x2,5	170	225	5000	25	1	201,25 TL
MDA 20 24 17 F	200	M24x3	170	225	5000	25	1	210,00 TL
MDA 20 30 17 F	200	M30x3	170	225	5000	25	1	218,75 TL
MDA 24 20 17 B	240	M20x1,5	170	235	7000	25	1	323,75 TL
MDA 24 20 17 E	240	M20x2,5	170	235	7000	25	1	323,75 TL
MDA 24 24 17 F	240	M24x3	170	235	8000	25	1	332,50 TL
MDA 24 30 17 F	240	M30x3	170	235	9000	25	1	341,25 TL

YENİ ÜRÜN

MDA MAKİNE DENGE AYAĞI CİVATASIZ



Ürün kodu	D	d	h	Kg	Pkt	Fiyat
MDA 80 10 B	80	M10x1,5	45	500	4	48,13 TL
MDA 80 12 A	80	M12x1,25	45	500	4	49,58 TL
MDA 80 16 B	80	M16x1,5	45	500	4	51,05 TL
MDA 80 16 D	80	M16x2	45	500	4	51,05 TL
MDA 12 10 B	120	M10x1,5	45	1000	4	71,45 TL
MDA 12 12 A	120	M12x1,25	45	1000	4	71,45 TL
MDA 12 16 B	120	M16x1,5	45	1000	4	72,92 TL
MDA 12 16 D	120	M16x2	45	1000	4	72,92 TL
MDA 16 16 B	160	M16x1,5	55	2000	1	113,75 TL
MDA 16 16 D	160	M16x2	55	2000	1	113,75 TL
MDA 16 20 B	160	M20x1,5	55	2000	1	116,67 TL
MDA 16 20 E	160	M20x2,5	55	2000	1	116,67 TL
MDA 20 20 B	200	M20x1,5	55	5000	1	182,30 TL
MDA 20 20 E	200	M20x2,5	55	5000	1	182,30 TL
MDA 20 24 F	200	M24x3	55	5000	1	189,58 TL
MDA 20 30 F	200	M30x3	55	5000	1	189,58 TL
MDA 24 20 B	240	M20x1,5	65	7000	1	291,67 TL
MDA 24 20 E	240	M20x2,5	65	7000	1	291,67 TL
MDA 24 24 F	240	M24x3	65	7000	1	294,58 TL
MDA 24 30 F	240	M30x3	65	7000	1	309,17 TL

MDAS MAKİNE DENGE AYAĞI SABİT

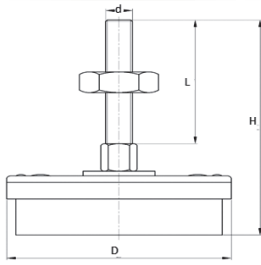

Ürün kodu	D	d	L	H	Kg	Pkt	Fiyat
MDAS 80 16 10	80	M16	100	156	600	4	56,00 TL
MDAS 80 16 15	80	M16	150	206	800	4	59,50 TL
MDAS 12 16 10	120	M16	100	158	1000	1	80,50 TL
MDAS 12 16 15	120	M16	150	208	1200	1	85,75 TL
MDAS 12 20 10	120	M20	100	158	1200	1	87,50 TL
MDAS 12 20 15	160	M20	150	208	1400	1	91,00 TL
MDAS 16 16 10	160	M20	100	164	2000	1	112,00 TL
MDAS 16 16 15	160	M16	150	214	2200	1	115,50 TL
MDAS 16 20 10	160	M20	100	164	2200	1	119,00 TL
MDAS 16 20 15	160	M20	150	214	2400	1	119,00 TL
MDAS 16 24 15	200	M24	150	214	2800	1	136,50 TL
MDAS 20 20 10	200	M20	100	219	3000	1	166,25 TL
MDAS 20 20 15	200	M20	150	219	3200	1	169,75 TL
MDAS 20 24 15	200	M24	150	219	3600	1	173,25 TL

MDASÇ MAKİNE DENGE AYAĞI SABİT Çinko



Ürün kodu	D	d	L	H	Kg	Pkt	Fiyat
MDASÇ 80 16 10	80	M16	100	156	600	4	49,00 TL
MDASÇ 80 16 15	80	M16	150	206	800	4	52,50 TL
MDASÇ 12 16 10	120	M16	100	158	1000	1	70,00 TL
MDASÇ 12 16 15	120	M16	150	208	1200	1	73,50 TL
MDASÇ 12 20 10	120	M20	100	158	1200	1	77,00 TL
MDASÇ 12 20 15	160	M20	150	208	1400	1	80,50 TL
MDASÇ 16 16 10	160	M16	100	164	2000	1	98,00 TL
MDASÇ 16 16 15	160	M16	150	214	2200	1	101,50 TL
MDASÇ 16 20 10	160	M20	100	164	2200	1	105,00 TL
MDASÇ 16 20 15	160	M20	150	214	2400	1	105,00 TL
MDASÇ 16 24 15	200	M24	150	214	2800	1	122,50 TL
MDASÇ 20 20 10	200	M20	100	219	3000	1	148,75 TL
MDASÇ 20 20 15	200	M20	150	219	3200	1	152,25 TL
MDASÇ 20 24 15	200	M24	150	219	3600	1	155,75 TL

MAS METAL AYAK SABİT

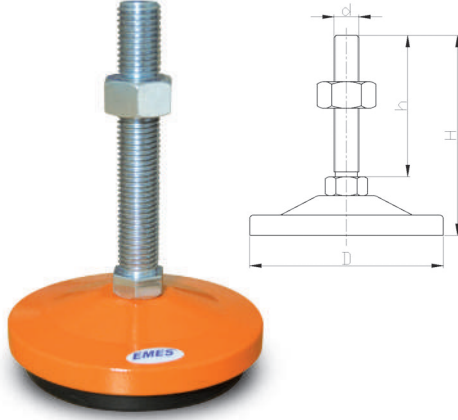

Ürün kodu	D	d	h	H	Sw	Kg	Pkt	Fiyat
MAS 60 16 10	60	M16	100	132	22	900	4	45,50 TL
MAS 60 16 15	60	M16	150	182	22	900	4	52,50 TL
MAS 80 16 10	80	M16	100	132	19	900	4	71,75 TL
MAS 80 16 15	80	M16	150	182	19	900	4	78,75 TL
MAS 80 20 10	80	M20	100	132	22	1200	4	78,75 TL
MAS 80 20 15	80	M20	150	182	22	1200	4	85,75 TL
MAS 10 16 10	100	M16	100	132	19	1200	4	85,75 TL
MAS 10 16 15	100	M16	150	182	19	1200	4	92,75 TL
MAS 10 20 10	100	M20	100	132	22	1500	4	92,75 TL
MAS 10 20 15	100	M20	150	182	22	1500	4	99,75 TL
MAS 10 24 15	100	M24	150	182	27	1500	4	106,75 TL

DA DÖKÜM AYAK



Ürün kodu	D	d	h	H	Kg	Pkt	Fiyat
DA 060 12 100	60	M12x1,5	100	135	400	6	52,50 TL
DA 080 12 100	80	M12x1,5	100	140	600	6	68,25 TL
DA 100 16 100	100	M16x1,5	100	145	750	4	80,50 TL
DA 120 16 100	120	M16x1,5	100	145	1000	4	105,00 TL
DA 140 16 100	140	M16x1,5	100	152	1500	2	119,00 TL
DA 160 20 100	160	M20x1,5	100	155	2500	2	157,50 TL

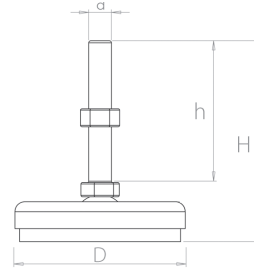

KT KAUÇUK TABAN

Ürün Kodu	L1xL2	H	Kg	Pkt	Fiyat
KT 100 20	100x100	20	500	4	28,00 TL
KT 100 30	100x100	30	500	4	31,50 TL
KT 120 20	120x120	20	750	4	31,50 TL
KT 120 30	120x120	20	750	4	38,50 TL
KT 150 20	150x150	30	1000	4	45,50 TL
KT 150 30	150x150	20	1000	4	52,50 TL
KT 200 20	200x200	30	1250	2	63,00 TL
KT 200 30	200x200	20	1250	2	73,50 TL

KTs KAUÇUK TABAN / Siyah

Ürün Kodu	L1xL2	H	Kg	Pkt	Fiyat
KTs 100 20	100x100	20	500	4	11,96 TL
KTs 100 30	100x100	30	500	4	15,46 TL
KTs 120 20	120x120	20	750	4	17,50 TL
KTs 120 30	120x120	20	750	4	22,46 TL
KTs 150 20	150x150	30	1000	4	29,46 TL
KTs 150 30	150x150	20	1000	4	36,46 TL
KTs 200 20	200x200	30	1250	2	58,33 TL
KTs 200 30	200x200	20	1250	2	72,92 TL

PAS PLASTİK AYAK SABİT



Ürün kodu	D	d	h	H	Sw	Kg	Pkt	Fiyat
PAS 12 16 10	125	M16	100	160	19	1500	4	31,50 TL
PAS 12 16 15	125	M16	150	210	19	1500	4	38,50 TL
PAS 12 20 10	125	M20	100	160	22	1500	4	42,00 TL
PAS 12 20 15	125	M20	150	210	22	1500	4	45,50 TL
PAS 12 24 15	125	M24	150	210	27	1500	4	52,50 TL
PAS 12 20 20	125	M20	200	260	22	1500	4	59,50 TL
PAS 12 20 25	125	M20	250	310	22	1500	4	66,50 TL
PAS 12 20 30	125	M20	300	360	22	1500	4	68,25 TL

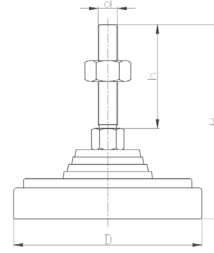

PRAB PLASTİK ROTİL AYAK BOMBELİ

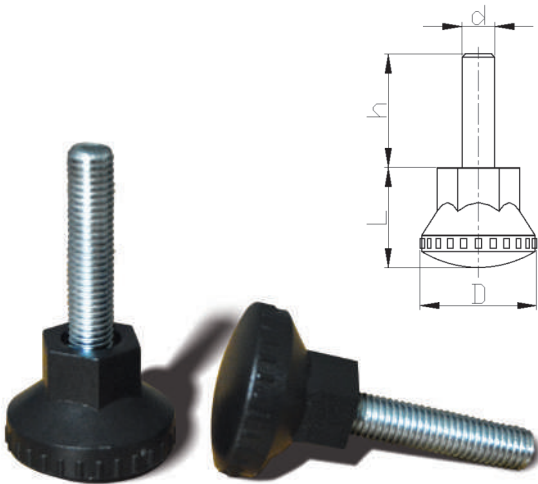

Ürün kodu	D	d	h	L	Kg	Pkt	Fiyat
PRAB 46 10 40	45	M10	40	33	75	50	3,41 TL
PRAB 46 10 50	45	M10	50	33	75	50	3,50 TL
PRAB 46 10 60	45	M10	60	33	75	50	3,76 TL
PRAB 46 12 40	45	M12	40	33	80	50	3,85 TL
PRAB 46 12 50	45	M12	50	33	80	50	3,94 TL
PRAB 46 12 60	45	M12	60	33	80	50	4,20 TL
PRAB 46 14 40	45	M14	40	33	85	50	4,38 TL
PRAB 46 14 50	45	M14	50	33	85	50	4,46 TL
PRAB 46 14 60	45	M14	60	33	85	50	4,73 TL
PRAB 46 16 40	45	M16	40	33	90	50	5,25 TL
PRAB 46 16 50	45	M16	50	33	90	50	5,34 TL
PRAB 46 16 60	45	M16	60	33	90	50	5,60 TL

SA SAC AYAK

Ürün kodu	D	d	h	H	Sw	Kg	Pkt	Fiyat
SA 10 12 90	100	M12	90	116	17	450	8	22,75 TL
SA 10 16 10	100	M16	100	126	24	550	8	28,00 TL
SA 10 20 15	100	M20	150	176	24	700	8	36,75 TL

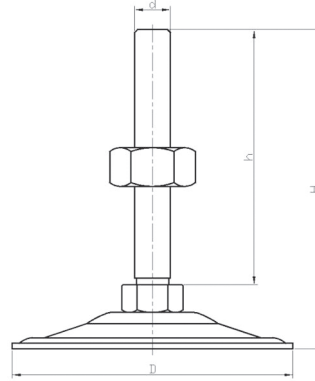
**SAi** SAC AYAK İNOX

Ürün kodu	D	d	h	H	Sw	Kg	Pkt	Fiyat
SAi 10 12 70	100	M12	70	96	17	450	8	40,25 TL
SAi 10 16 10	100	M16	100	126	24	550	8	50,75 TL
SAi 10 20 10	100	M20	100	126	24	700	8	80,50 TL

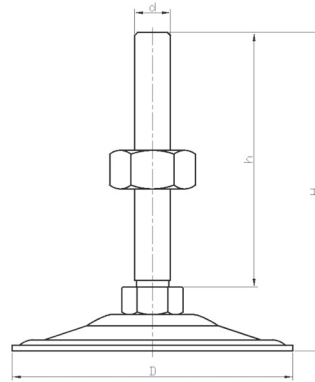

PAMB PLASTİK AYAK MAFSALLI BURÇLU



Ürün kodu	D	d	h	H	Sw	Kg	Pkt	Fiyat
PAMB 60 12	60	M12	24	47	19	500	10	14,00 TL
PAMB 60 16	60	M16	24	47	19	500	10	14,00 TL
PAMB 80 12	80	M12	24	47	19	600	10	14,88 TL
PAMB 80 16	80	M16	24	47	19	600	10	14,88 TL
PAMB 11 12	110	M12	24	47	19	1000	4	17,50 TL
PAMB 11 16	110	M16	24	47	19	1000	4	17,50 TL

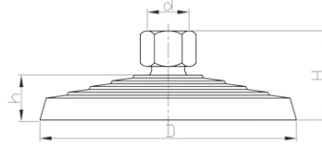

KKAB KROM KAPLI AYAK BURÇLU



Ürün kodu	D	d	h	H	Sw	Kg	Pkt	Fiyat
KKAB 60 10	60	M10	26	43	24	400	10	22,75 TL
KKAB 60 12	60	M12	26	43	24	400	10	24,50 TL
KKAB 60 16	60	M16	26	43	24	400	10	26,25 TL
KKAB 80 10	80	M10	29	46	24	600	10	29,75 TL
KKAB 80 12	80	M12	29	46	24	600	10	31,50 TL
KKAB 80 16	80	M16	29	46	24	600	10	35,00 TL
KKAB 10 10	100	M10	29	46	24	800	10	35,00 TL
KKAB 10 12	100	M12	29	46	24	800	10	36,75 TL
KKAB 10 16	100	M16	29	46	24	800	10	38,50 TL
KKAB 12 10	120	M10	34	51	24	1000	4	42,00 TL
KKAB 12 12	120	M12	34	51	24	1000	4	43,75 TL
KKAB 12 16	120	M16	34	51	24	1000	4	45,50 TL

İAB İNOX AYAK BURÇLU

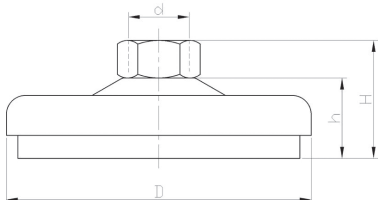

Ürün kodu	D	d	h	H	Sw	Kg	Pkt	Fiyat
İAB 60 10	60	M10	26	43	24	400	10	43,75 TL
İAB 60 12	60	M12	26	43	24	400	10	43,75 TL
İAB 60 16	60	M16	26	43	24	400	10	43,75 TL
İAB 80 10	80	M10	29	46	24	600	10	52,50 TL
İAB 80 12	80	M12	29	46	24	600	10	52,50 TL
İAB 80 16	80	M16	29	46	24	600	10	52,50 TL
İAB 10 10	100	M10	29	46	24	800	10	66,50 TL
İAB 10 12	100	M12	29	46	24	800	10	66,50 TL
İAB 10 16	100	M16	29	46	24	800	10	66,50 TL
İAB 12 10	120	M10	34	51	24	1000	4	80,50 TL
İAB 12 12	120	M12	34	51	24	1000	4	80,50 TL
İAB 12 16	120	M16	34	51	24	1000	4	80,50 TL

ÇDKK ÇELİK DÖNER KATLANIR KOL



Ürün kodu	D	d	h	L	Pkt	Fiyat
ÇDKK 50 06	20	M6	19,5	50	25	21,88 TL
ÇDKK 50 08	20	M8	19,5	50	25	22,75 TL
ÇDKK 70 08	20	M8	19,5	70	25	23,63 TL
ÇDKK 70 10	20	M10	19,5	70	25	24,50 TL

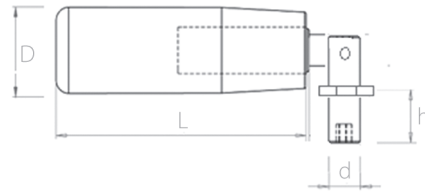

KKÇK KROM KAPLI ÇELİK KOL



Ürün kodu	D	d	h	L	Pkt	Fiyat
KKÇK 20 54 06	20	M6	10	54	5	28,00 TL
KKÇK 20 54 08	20	M8	11	54	5	28,00 TL
KKÇK 20 54 10	20	M10	14	54	5	28,00 TL
KKÇK 22 72 06	22	M6	10	72	5	29,75 TL
KKÇK 22 72 08	22	M8	11	72	5	29,75 TL
KKÇK 22 72 10	22	M10	14	72	5	29,75 TL
KKÇK 24 88 06	27	M6	10	88	5	31,50 TL
KKÇK 24 88 08	27	M8	11	88	5	31,50 TL
KKÇK 24 88 10	27	M10	14	88	5	31,50 TL



DÇ DÖKÜM ÇARK

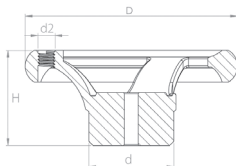

Ürün kodu	D	H	d	d2	Pkt	Fiyat
DÇ 75 30 16	75	35	30	-	1	56,88 TL
DÇ 85 35 16	85	40	35	M8	1	67,38 TL
DÇ 10 40 16	100	45	40	M10	1	70,88 TL
DÇ 12 45 16	125	50	45	M10	1	87,50 TL
DÇ 15 50 24	150	55	50	M10	1	134,75 TL
DÇ 18 55 24	180	60	55	M10	1	148,75 TL
DÇ 20 60 24	200	60	60	M10	1	164,50 TL
DÇ 25 65 24	250	65	65	M10	1	259,00 TL
DÇ 30 70 24	300	75	70	M10	1	385,00 TL

DK

DÖKÜM KOL



Ürün kodu	L	D	SxS	h1	h2	h3	h4	Pkt	Fiyat
DK 100 14X14	100	28	14x14	29	13	60	50	4	94,79 TL
DK 125 17X17	125	34	17x17	34	13	67	50	4	105,00 TL
DK 160 19X19	160	38	19x19	40	14	77	64	1	119,58 TL
DK 200 22X22	200	44	22x22	45	21	95	81	1	148,75 TL
DK 250 24X24	250	47	24x24	53	21	114	81	1	160,42 TL

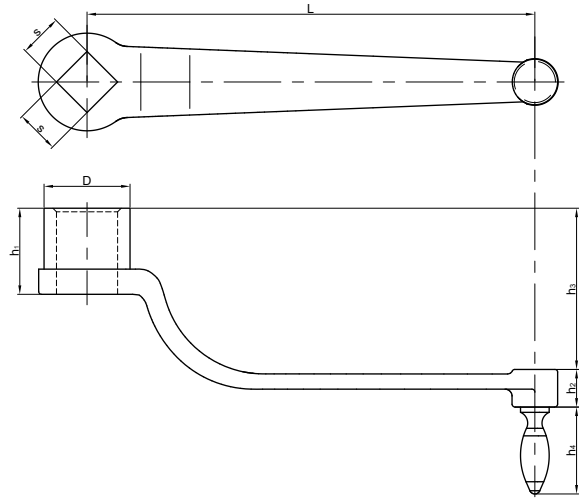

PRd PLASTİK ROTİL / Dikdörtgen

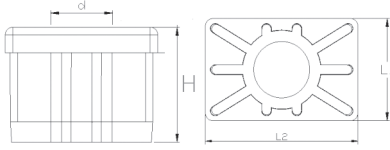

Ürün kodu	L1xL2	d	H	T	Kg	Pkt	Fiyat
PRd 30 40 10	30x40	M10	38	1,5	330	100	2,36 TL
PRd 30 40 12	30x40	M12	38	1,5	330	100	2,54 TL
PRd 30 50 10	30x50	M10	38	1,5	400	100	3,24 TL
PRd 30 50 12	30x50	M12	38	1,5	400	100	3,41 TL
PRd 40 60 10	40x60	M10	45	1,5	525	25	4,11 TL
PRd 40 60 12	40x60	M12	45	1,5	525	25	4,29 TL
PRd 40 60 14	40x60	M14	45	1,5	575	25	4,46 TL
PRd 40 60 16	40x60	M16	45	1,5	600	25	4,81 TL

PRk PLASTİK ROTİL / Kare

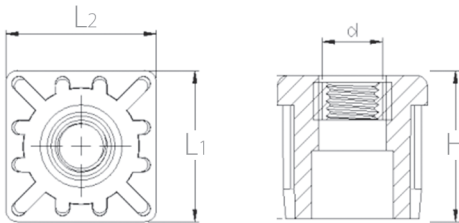

Ürün kodu	L1xL2	d	H	T	Kg	Pkt	Fiyat
PRk 25 25 10	25x25	M10		1,5		100	1,46 TL
PRk 30 30 10	30x30	M10	30	1,5	300	100	1,75 TL
PRk 30 30 12	30x30	M12	30	1,5	325	100	1,93 TL
PRk 40 40 10	40x40	M10	38	1,5	400	50	2,80 TL
PRk 40 40 12	40x40	M12	38	1,5	400	50	2,98 TL
PRk 40 40 14	40x40	M14	38	1,5	450	50	3,15 TL
PRk 40 40 16	40x40	M16	38	1,5	500	50	3,50 TL
PRk 50 50 10	50x50	M10	45	1,5	525	25	4,46 TL
PRk 50 50 12	50x50	M12	45	1,5	525	25	4,64 TL
PRk 50 50 14	50x50	M14	45	1,5	575	25	4,81 TL
PRk 50 50 16	50x50	M16	45	1,5	600	25	5,16 TL

PRA PLASTİK ROTİL AYAK

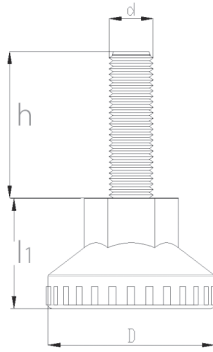

Ürün kodu	D	d	h	l1	Kg	Pkt	Fiyat
PRA 35 10 40	35	M10	40	26	50	100	2,01 TL
PRA 35 10 50	35	M10	50	26	50	100	2,10 TL
PRA 35 10 60	35	M10	60	26	50	100	2,36 TL
PRA 35 12 40	35	M12	40	26	55	100	2,45 TL
PRA 35 12 50	35	M12	50	26	55	100	2,54 TL
PRA 35 12 60	35	M12	60	26	55	100	2,80 TL
PRA 45 10 40	45	M10	40	30	75	50	3,06 TL
PRA 45 10 50	45	M10	50	30	75	50	3,15 TL
PRA 45 10 60	45	M10	60	30	75	50	3,41 TL
PRA 45 12 40	45	M12	40	30	80	50	3,50 TL
PRA 45 12 50	45	M12	50	30	80	50	3,59 TL
PRA 45 12 60	45	M12	60	30	80	50	3,85 TL
PRA 45 14 40	45	M14	40	30	85	50	3,94 TL
PRA 45 14 50	45	M14	50	30	85	50	4,11 TL
PRA 45 14 60	45	M14	60	30	85	50	4,46 TL
PRA 45 16 40	45	M16	40	30	90	50	4,73 TL
PRA 45 16 50	45	M16	50	30	90	50	5,25 TL
PRA 45 16 60	45	M16	60	30	90	50	5,60 TL
PRA 55 10 40	55	M10	40	35	100	50	4,38 TL
PRA 55 10 50	55	M10	50	35	100	50	4,46 TL
PRA 55 10 60	55	M10	60	35	100	50	4,73 TL
PRA 55 12 40	55	M12	40	35	125	50	4,81 TL
PRA 55 12 50	55	M12	50	35	125	50	4,90 TL
PRA 55 12 60	55	M12	60	35	125	50	5,16 TL
PRA 55 14 40	55	M14	40	35	150	50	5,25 TL
PRA 55 14 50	55	M14	50	35	150	50	5,43 TL
PRA 55 14 60	55	M14	60	35	150	50	5,78 TL
PRA 55 16 40	55	M16	40	35	175	50	6,04 TL
PRA 55 16 50	55	M16	50	35	175	50	6,56 TL
PRA 55 16 60	55	M16	60	35	175	50	6,91 TL

PPA PLASTİK PİNYON AYAK

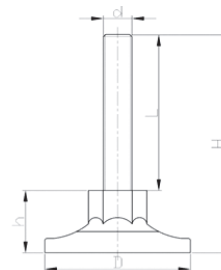

Ürün kodu	D	d	L	h	H	Kg	Pkt	Fiyat
PPA 60 10 70	60	M10	70	28	98	150	50	5,25 TL
PPA 60 12 70	60	M12	70	28	98	250	50	7,00 TL
PPA 60 16 80	60	M16	80	28	108	400	50	8,75 TL

PDKK PLASTİK DÖNER KATLANIR KOL



Ürün kodu	L	d	D	h	Pkt	Fiyat
PDKK 55 06	55	M6	20	19,5	50	18,38 TL
PDKK 55 08	55	M8	20	19,5	50	19,25 TL
PDKK 55 10	55	M10	20	19,5	50	20,13 TL
PDKK 70 06	70	M6	25	19,5	50	21,00 TL
PDKK 70 08	70	M8	25	19,5	50	21,88 TL
PDKK 70 10	70	M10	25	19,5	50	22,75 TL

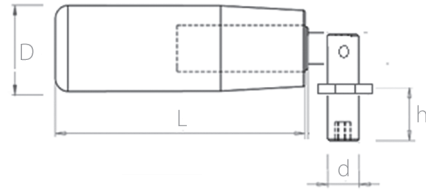

PDK PLASTİK DÖNER KOL



Ürün kodu	L	d	D	h	Pkt	Fiyat
PDK 55 06	55	M6	20	15,3	50	12,25 TL
PDK 55 08	55	M8	20	15,3	50	12,95 TL
PDK 55 10	55	M10	20	15,3	50	13,65 TL
PDK 70 06	70	M6	25	15,3	50	12,95 TL
PDK 70 08	70	M8	25	15,3	50	13,65 TL
PDK 70 10	70	M10	25	15,3	50	14,35 TL

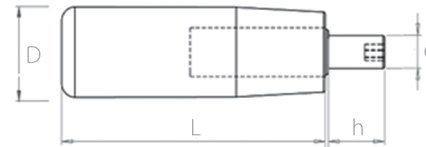

PÇ PLASTİK ÇARK



Ürün kodu	D	d	d1	H	Pkt	Fiyat
PÇ 100 06	100	M6	28	40	1	22,75 TL
PÇ 125 08	125	M8	30	45	1	26,25 TL
PÇ 150 08	150	M8	50	50	1	40,25 TL
PÇ 150 10	150	M10	50	50	1	40,25 TL
PÇ 200 08	200	M8	50	55	1	47,25 TL
PÇ 200 10	200	M10	50	55	1	47,25 TL

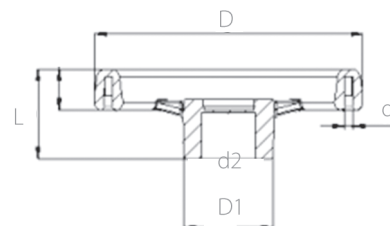

PKBi PLASTİK KOL BURÇLU / INOX



Ürün kodu	l1	d	h	H	Pkt	Fiyat
PKBi 63 06	63	M6	12	45,5	50	17,50 TL
PKBi 63 08	63	M8	12	45,5	50	18,20 TL
PKBi 63 10	63	M10	12	45,5	50	18,90 TL
PKBi 63 12	63	M12	12	45,5	50	19,60 TL
PKBi 78 06	78	M6	12	45,5	50	19,25 TL
PKBi 78 08	78	M8	12	45,5	50	19,95 TL
PKBi 78 10	78	M10	12	45,5	50	20,65 TL
PKBi 78 12	78	M12	12	45,5	50	21,35 TL

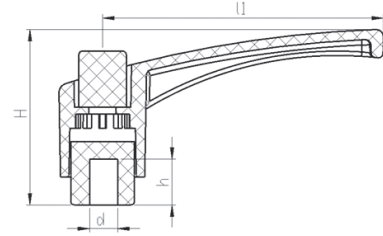

PKCi PLASTİK KOL CİVATALI / INOX



Ürün kodu	l1	d	h	H	Pkt	Fiyat
PKCi 63 06 30	63	M6	30	45,5	50	21,35 TL
PKCi 63 08 30	63	M8	30	45,5	50	22,23 TL
PKCi 63 10 30	63	M10	30	45,5	50	22,93 TL
PKCi 63 12 30	63	M12	30	45,5	50	23,63 TL
PKCi 78 06 30	78	M6	30	45,5	50	22,93 TL
PKCi 78 08 30	78	M8	30	45,5	50	23,63 TL
PKCi 78 10 30	78	M10	30	45,5	50	24,50 TL
PKCi 78 12 30	78	M12	30	45,5	50	25,38 TL

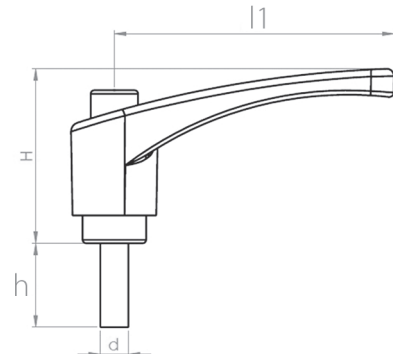

PKB PLASTİK KOL BURÇLU



Ürün kodu	l1	d	h	H	Pkt	Fiyat
PKB 63 06	63	M6	12	45,5	50	8,05 TL
PKB 63 08	63	M8	12	45,5	50	8,40 TL
PKB 63 10	63	M10	12	45,5	50	8,75 TL
PKB 63 12	63	M12	12	45,5	50	9,10 TL
PKB 78 06	78	M6	12	45,5	50	8,40 TL
PKB 78 08	78	M8	12	45,5	50	8,75 TL
PKB 78 10	78	M10	12	45,5	50	9,10 TL
PKB 78 12	78	M12	12	45,5	50	9,45 TL

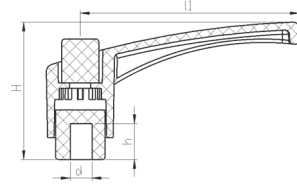

PKC PLASTİK KOL CİVATALI



Ürün kodu	l1	d	h	H	Pkt	Fiyat
PKC 63 06 30	63	M6	30	45,5	50	9,10 TL
PKC 63 06 40	63	M6	40	45,5	50	9,45 TL
PKC 63 08 30	63	M8	30	45,5	50	9,45 TL
PKC 63 08 40	63	M8	40	45,5	50	9,80 TL
PKC 63 08 50	63	M8	50	45,5	50	10,15 TL
PKC 63 10 30	63	M10	30	45,5	50	9,80 TL
PKC 63 10 40	63	M10	40	45,5	50	10,15 TL
PKC 63 10 50	63	M10	50	45,5	50	10,50 TL
PKC 63 10 60	63	M10	60	45,5	50	10,85 TL
PKC 63 12 30	63	M12	30	45,5	50	10,15 TL
PKC 63 12 40	63	M12	40	45,5	50	10,50 TL
PKC 63 12 50	63	M12	50	45,5	50	10,85 TL
PKC 63 12 60	63	M12	60	45,5	50	11,20 TL
PKC 78 06 30	78	M6	30	45,5	50	9,45 TL
PKC 78 06 40	78	M6	40	45,5	50	9,80 TL
PKC 78 08 30	78	M8	30	45,5	50	9,80 TL
PKC 78 08 40	78	M8	40	45,5	50	10,15 TL
PKC 78 08 50	78	M8	50	45,5	50	10,50 TL
PKC 78 10 30	78	M10	30	45,5	50	10,15 TL
PKC 78 10 40	78	M10	40	45,5	50	10,50 TL
PKC 78 10 50	78	M10	50	45,5	50	10,85 TL
PKC 78 10 60	78	M10	60	45,5	50	11,20 TL
PKC 78 12 30	78	M12	30	45,5	50	10,50 TL
PKC 78 12 40	78	M12	40	45,5	50	10,85 TL
PKC 78 12 50	78	M12	50	45,5	50	11,20 TL
PKC 78 12 60	78	M12	60	45,5	50	11,55 TL

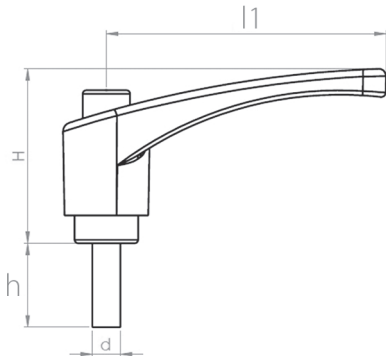

PKBit PLASTİK KOL BURÇLU INOX/Turuncu



Ürün kodu	l1	d	h	H	Pkt	Fiyat
PKBit 63 06	63	M6	12	45,5	50	18,90 TL
PKBit 63 08	63	M8	12	45,5	50	19,60 TL
PKBit 63 10	63	M10	12	45,5	50	20,30 TL
PKBit 63 12	63	M12	12	45,5	50	21,00 TL
PKBit 78 06	78	M6	12	45,5	50	20,65 TL
PKBit 78 08	78	M8	12	45,5	50	21,35 TL
PKBit 78 10	78	M10	12	45,5	50	22,05 TL
PKBit 78 12	78	M12	12	45,5	50	22,75 TL

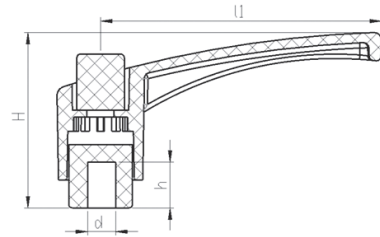

PKÇit PLASTİK KOL CİVATALI INOX/Turuncu



Ürün kodu	l1	d	h	H	Pkt	Fiyat
PKÇit 63 06 30	63	M6	30	45,5	50	22,75 TL
PKÇit 63 08 30	63	M8	30	45,5	50	23,63 TL
PKÇit 63 10 30	63	M10	30	45,5	50	24,33 TL
PKÇit 63 12 30	63	M12	30	45,5	50	25,03 TL
PKÇit 78 06 30	78	M6	30	45,5	50	24,33 TL
PKÇit 78 08 30	78	M8	30	45,5	50	25,03 TL
PKÇit 78 10 30	78	M10	30	45,5	50	25,90 TL
PKÇit 78 12 30	78	M12	30	45,5	50	26,78 TL

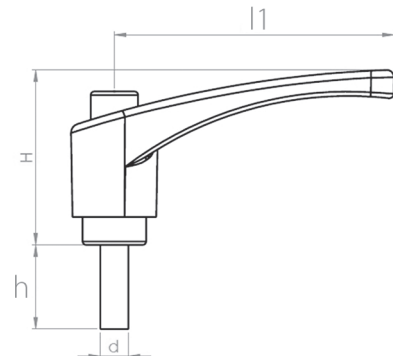

PKBt PLASTİK KOL BURÇLU/ Turuncu



Ürün kodu	l1	d	h	H	Pkt	Fiyat
PKBt 63 06	63	M6	12	45,5	50	9,45 TL
PKBt 63 08	63	M8	12	45,5	50	9,80 TL
PKBt 63 10	63	M10	12	45,5	50	10,15 TL
PKBt 63 12	63	M12	12	45,5	50	10,50 TL
PKBt 78 06	78	M6	12	45,5	50	9,80 TL
PKBt 78 08	78	M8	12	45,5	50	10,15 TL
PKBt 78 10	78	M10	12	45,5	50	10,50 TL
PKBt 78 12	78	M12	12	45,5	50	10,85 TL

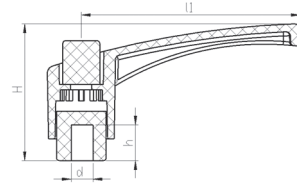

PKCt PLASTİK KOL CİVATALI/ Turuncu



Ürün kodu	l1	d	h	H	Pkt	Fiyat
PKCt 63 06 30	65	M6	30	45,5	50	10,50 TL
PKCt 63 06 40	65	M6	40	45,5	50	10,85 TL
PKCt 63 08 30	65	M8	30	45,5	50	10,85 TL
PKCt 63 08 40	65	M8	40	45,5	50	11,20 TL
PKCt 63 08 50	65	M8	50	45,5	50	11,55 TL
PKCt 63 10 30	65	M10	30	45,5	50	11,20 TL
PKCt 63 10 40	65	M10	40	45,5	50	11,55 TL
PKCt 63 10 50	65	M10	50	45,5	50	11,90 TL
PKCt 63 10 60	65	M10	60	45,5	50	12,25 TL
PKCt 63 12 30	65	M12	30	45,5	50	11,55 TL
PKCt 63 12 40	65	M12	40	45,5	50	11,90 TL
PKCt 63 12 50	65	M12	50	45,5	50	12,25 TL
PKCt 63 12 60	65	M12	60	45,5	50	12,60 TL
PKCt 78 06 30	65	M6	30	45,5	50	10,85 TL
PKCt 78 06 40	65	M6	40	45,5	50	11,20 TL
PKCt 78 08 30	65	M8	30	45,5	50	11,20 TL
PKCt 78 08 40	65	M8	40	45,5	50	11,55 TL
PKCt 78 08 50	65	M8	50	45,5	50	11,90 TL
PKCt 78 10 30	65	M10	30	45,5	50	11,55 TL
PKCt 78 10 40	65	M10	40	45,5	50	11,90 TL
PKCt 78 10 50	65	M10	50	45,5	50	12,25 TL
PKCt 78 10 60	65	M10	60	45,5	50	12,60 TL
PKCt 78 12 30	65	M12	30	45,5	50	11,90 TL
PKCt 78 12 40	65	M12	40	45,5	50	12,25 TL
PKCt 78 12 50	65	M12	50	45,5	50	12,60 TL
PKCt 78 12 60	65	M12	60	45,5	50	12,95 TL

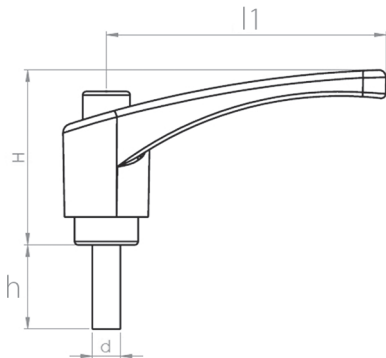

ZKC ZAMAK KOL CİVATALI

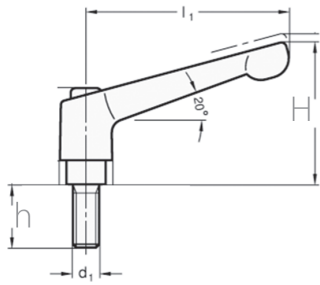

Ürün kodu	l1	d	h	H	Pkt	Fiyat
ZKC 63 0515	63	M5	15	55	10	24,75 TL
ZKC 63 0530	63	M5	30	70	10	24,75 TL
ZKC 63 0615	63	M6	15	55	10	24,75 TL
ZKC 63 0630	63	M6	30	70	10	24,75 TL
ZKC 63 0650	63	M6	50	90	10	24,75 TL
ZKC 78 0825	78	M8	25	80	10	30,20 TL
ZKC 78 0830	78	M8	30	85	10	30,20 TL
ZKC 78 0835	78	M8	35	90	10	30,20 TL
ZKC 78 0850	78	M8	50	105	10	30,20 TL
ZKC 78 1025	78	M10	25	80	10	30,20 TL
ZKC 78 1030	78	M10	30	85	10	30,20 TL
ZKC 78 1035	78	M10	35	90	10	30,20 TL
ZKC 78 1050	78	M10	50	105	10	30,20 TL
ZKC 78 1230	78	M12	30	85	10	30,20 TL
ZKC 78 1250	78	M12	50	105	10	30,20 TL
ZKC 92 1030	92	M10	30	95	10	44,00 TL
ZKC 92 1050	92	M10	50	115	10	44,00 TL
ZKC 92 1230	92	M12	30	95	10	44,00 TL
ZKC 92 1250	92	M12	50	115	10	44,00 TL
ZKC 11 1230	108	M12	30	108	10	55,00 TL
ZKC 11 1250	108	M12	50	128	10	55,00 TL
ZKC 11 1440	108	M14	40	118	10	55,00 TL
ZKC 11 1460	108	M14	60	138	10	55,00 TL
ZKC 11 1640	108	M16	40	118	10	55,00 TL
ZKC 11 1660	108	M16	60	138	10	55,00 TL

ZKB ZAMAK KOL BURÇLU

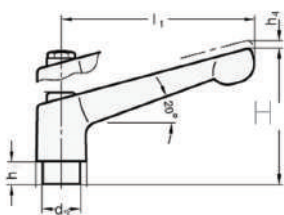

Ürün kodu	l1	d	h	H	Pkt	Fiyat
ZKB 63 06	63	M6	11	40	10	24,75 TL
ZKB 63 08	63	M8	11	40	10	24,75 TL
ZKB 63 10	63	M10	11	40	10	24,75 TL
ZKB 78 08	78	M8	14	55	10	30,20 TL
ZKB 78 10	78	M10	14	55	10	30,20 TL
ZKB 78 12	78	M12	14	55	10	30,20 TL
ZKB 92 10	92	M10	17	65	10	44,00 TL
ZKB 92 12	92	M12	17	65	10	44,00 TL
ZKB 11 12	108	M12	22	78	10	55,00 TL
ZKB 11 14	108	M14	22	78	10	55,00 TL
ZKB 11 16	108	M16	22	78	10	55,00 TL

ZKcT ZAMAK KOL CİVATALI / Turuncu

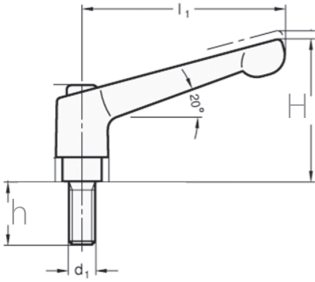

YENİ ÜRÜN

Ürün kodu	l1	d	h	H	Pkt	Fiyat
ZKcT 63 0515	63	M5	15	55	10	24,75 TL
ZKcT 63 0530	63	M5	30	70	10	24,75 TL
ZKcT 63 0615	63	M6	15	55	10	24,75 TL
ZKcT 63 0630	63	M6	30	70	10	24,75 TL
ZKcT 63 0650	63	M6	50	90	10	24,75 TL
ZKcT 78 0825	78	M8	25	80	10	30,20 TL
ZKcT 78 0830	78	M8	30	85	10	30,20 TL
ZKcT 78 0835	78	M8	35	90	10	30,20 TL
ZKcT 78 0850	78	M8	50	105	10	30,20 TL
ZKcT 78 1025	78	M10	25	80	10	30,20 TL
ZKcT 78 1030	78	M10	30	85	10	30,20 TL
ZKcT 78 1035	78	M10	35	90	10	30,20 TL
ZKcT 78 1050	78	M10	50	105	10	30,20 TL
ZKcT 78 1230	78	M12	30	85	10	30,20 TL
ZKcT 78 1250	78	M12	50	105	10	30,20 TL
ZKcT 92 1030	92	M10	30	95	10	44,00 TL
ZKcT 92 1050	92	M10	50	115	10	44,00 TL
ZKcT 92 1230	92	M12	30	95	10	44,00 TL
ZKcT 92 1250	92	M12	50	115	10	44,00 TL
ZKcT 11 1230	108	M12	30	108	10	55,00 TL
ZKcT 11 1250	108	M12	50	128	10	55,00 TL
ZKcT 11 1440	108	M14	40	118	10	55,00 TL
ZKcT 11 1460	108	M14	60	138	10	55,00 TL
ZKcT 11 1640	108	M16	40	118	10	55,00 TL
ZKcT 11 1660	108	M16	60	138	10	55,00 TL

ZKBt ZAMAK KOL BURÇLU / Turuncu

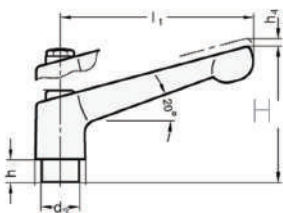

YENİ ÜRÜN

Ürün kodu	l1	d	h	H	Pkt	Fiyat
ZKBt 63 06	63	M6	11	40	10	24,75 TL
ZKBt 63 08	63	M8	11	40	10	24,75 TL
ZKBt 63 10	63	M10	11	40	10	24,75 TL
ZKBt 78 08	78	M8	14	55	10	30,20 TL
ZKBt 78 10	78	M10	14	55	10	30,20 TL
ZKBt 78 12	78	M12	14	55	10	30,20 TL
ZKBt 92 10	92	M10	17	65	10	44,00 TL
ZKBt 92 12	92	M12	17	65	10	44,00 TL
ZKBt 11 12	108	M12	22	78	10	55,00 TL
ZKBt 11 14	108	M14	22	78	10	55,00 TL
ZKBt 11 16	108	M16	22	78	10	55,00 TL

PT PLASTİK TUTAMAK



■ RAL 7021 Siyah

Ürün kodu	L	L1	d	h	Pkt	Fiyat
PT 11 08	137	117	M8	41	50	2,98 TL
PT 14 08	160	140	M8	46	50	4,11 TL

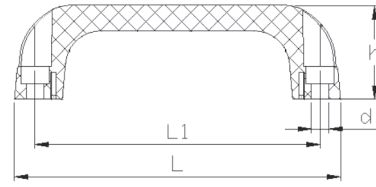

PTt PLASTİK TUTAMAK / Turuncu



■ RAL 2004 Turuncu

Ürün kodu	L	L1	d	h	Pkt	Fiyat
PTt 11 08	137	117	M8	41	50	4,11 TL
PTt 14 08	160	140	M8	46	50	5,16 TL

PTk PLASTİK TUTAMAK / Kırmızı



■ RAL 3000 Kırmızı

Ürün kodu	L	L1	d	h	Pkt	Fiyat
PTk 11 08	137	117	M8	41	50	4,11 TL
PTk 14 08	160	140	M8	46	50	5,16 TL

PYB PLASTİK YONCA BURÇLU

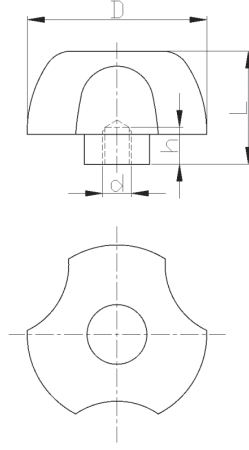

■ RAL 7021 Siyah

Ürün kodu	D	d	h	Pkt	Fiyat
PYB 40 06	40	M06	10	100	6,39 TL
PYB 40 08	40	M08	14	100	7,00 TL
PYB 40 10	40	M10	17	100	7,61 TL
PYB 50 08	50	M08	14	50	7,70 TL
PYB 50 10	50	M10	17	50	8,49 TL
PYB 63 10	63	M10	17	25	10,41 TL
PYB 63 12	63	M12	19	25	11,90 TL
PYB 63 16	63	M16	27	25	17,50 TL

PYC PLASTİK YONCA CİVATALI

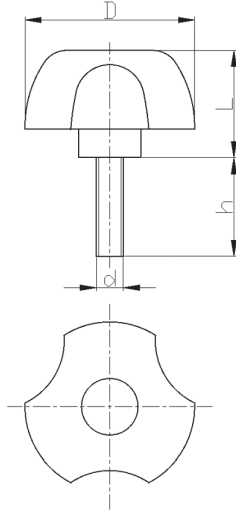

■ RAL 7021 Siyah

Ürün kodu	D	d	h	Pkt	Fiyat
PYC 40 06 15	40	M06	15	100	6,39 TL
PYC 40 06 20	40	M06	20	100	6,56 TL
PYC 40 06 30	40	M06	30	100	6,83 TL
PYC 40 06 40	40	M06	40	100	7,00 TL
PYC 40 08 20	40	M08	20	100	7,00 TL
PYC 40 08 30	40	M08	30	100	7,26 TL
PYC 40 08 40	40	M08	40	100	7,61 TL
PYC 40 10 20	40	M10	20	100	7,61 TL
PYC 40 10 30	40	M10	30	100	7,70 TL
PYC 40 10 40	40	M10	40	100	8,23 TL
PYC 40 10 50	40	M10	50	100	8,49 TL
PYC 50 08 20	50	M08	20	50	7,70 TL
PYC 50 08 30	50	M08	30	50	7,88 TL
PYC 50 08 40	50	M08	40	50	8,23 TL
PYC 50 10 20	50	M10	20	50	8,49 TL
PYC 50 10 30	50	M10	30	50	8,93 TL
PYC 50 10 40	50	M10	40	50	9,54 TL
PYC 50 10 50	50	M10	50	50	9,80 TL
PYC 63 10 20	63	M10	20	25	10,41 TL
PYC 63 10 30	63	M10	30	25	10,85 TL
PYC 63 10 40	63	M10	40	25	11,46 TL
PYC 63 10 50	63	M10	50	25	11,73 TL
PYC 63 12 40	63	M12	40	25	11,90 TL
PYC 63 16 50	63	M16	50	25	15,75 TL

PYBt PLASTİK YONCA BURÇLU/ Turuncu

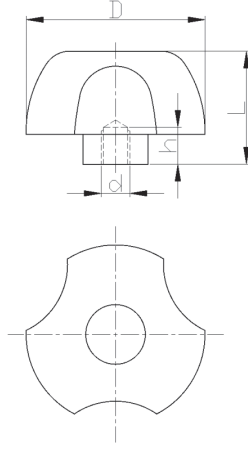

RAL 2004 Turuncu

Ürün kodu	D	d	h	Pkt	Fiyat
PYBt 40 06	40	M06	10	100	7,44 TL
PYBt 40 08	40	M08	14	100	8,05 TL
PYBt 40 10	40	M10	17	100	8,66 TL
PYBt 50 08	50	M08	14	50	8,75 TL
PYBt 50 10	50	M10	17	50	9,54 TL
PYBt 63 10	63	M10	17	25	11,46 TL
PYBt 63 12	63	M12	19	25	12,95 TL
PYBt 63 16	63	M16	27	25	18,55 TL

PYct PLASTİK YONCA CİVATALI/ Turuncu

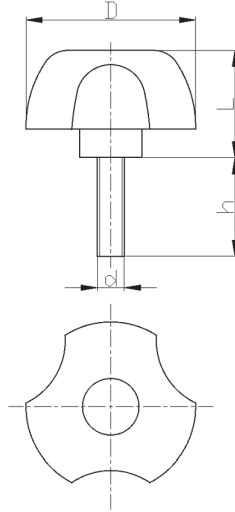

RAL 2004 Turuncu

Ürün kodu	D	d	h	Pkt	Fiyat
PYct 40 06 15	40	M06	15	100	7,44 TL
PYct 40 06 20	40	M06	20	100	7,61 TL
PYct 40 06 30	40	M06	30	100	7,88 TL
PYct 40 06 40	40	M06	40	100	8,05 TL
PYct 40 08 20	40	M08	20	100	8,05 TL
PYct 40 08 30	40	M08	30	100	8,31 TL
PYct 40 08 40	40	M08	40	100	8,66 TL
PYct 40 10 20	40	M10	20	100	8,66 TL
PYct 40 10 30	40	M10	30	100	8,75 TL
PYct 40 10 40	40	M10	40	100	9,28 TL
PYct 40 10 50	40	M10	50	100	9,54 TL
PYct 50 08 20	50	M08	20	50	8,75 TL
PYct 50 08 30	50	M08	30	50	8,93 TL
PYct 50 08 40	50	M08	40	50	9,28 TL
PYct 50 10 20	50	M10	20	50	9,54 TL
PYct 50 10 30	50	M10	30	50	9,98 TL
PYct 50 10 40	50	M10	40	50	10,59 TL
PYct 50 10 50	50	M10	50	50	10,85 TL
PYct 63 10 20	63	M10	20	25	11,46 TL
PYct 63 10 30	63	M10	30	25	11,90 TL
PYct 63 10 40	63	M10	40	25	12,51 TL
PYct 63 10 50	63	M10	50	25	12,78 TL
PYct 63 12 40	63	M12	40	25	12,95 TL
PYct 63 16 50	63	M16	50	25	16,80 TL

PYBk PLASTİK YONCA BURÇLU/ Kırmızı

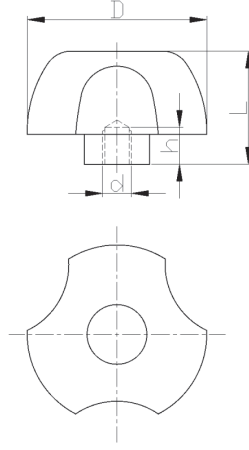

■ RAL 3000 Kırmızı

Ürün kodu	D	d	h	Pkt	Fiyat
PYBk 40 06	40	M06	10	100	7,44 TL
PYBk 40 08	40	M08	14	100	8,05 TL
PYBk 40 10	40	M10	17	100	8,66 TL
PYBk 50 08	50	M08	14	50	8,75 TL
PYBk 50 10	50	M10	17	50	9,54 TL
PYBk 63 10	63	M10	17	25	11,46 TL
PYBk 63 12	63	M12	19	25	12,95 TL
PYBk 63 16	63	M16	27	25	18,55 TL

PYck PLASTİK YONCA CİVATALI/ Kırmızı

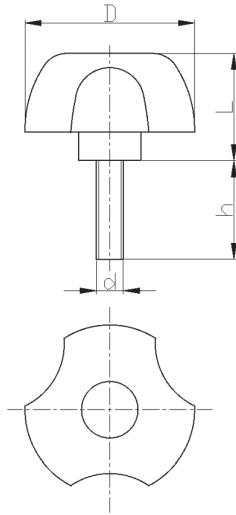
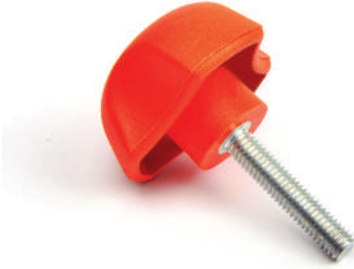

■ RAL 3000 Kırmızı

Ürün kodu	D	d	h	Pkt	Fiyat
PYck 40 06 15	40	M06	15	100	7,44 TL
PYck 40 06 20	40	M06	20	100	7,61 TL
PYck 40 06 30	40	M06	30	100	7,88 TL
PYck 40 06 40	40	M06	40	100	8,05 TL
PYck 40 08 20	40	M08	20	100	8,05 TL
PYck 40 08 30	40	M08	30	100	8,31 TL
PYck 40 08 40	40	M08	40	100	8,66 TL
PYck 40 10 20	40	M10	20	100	8,66 TL
PYck 40 10 30	40	M10	30	100	8,75 TL
PYck 40 10 40	40	M10	40	100	9,28 TL
PYck 40 10 50	40	M10	50	100	9,54 TL
PYck 50 08 20	50	M08	20	50	8,75 TL
PYck 50 08 30	50	M08	30	50	8,93 TL
PYck 50 08 40	50	M08	40	50	9,28 TL
PYck 50 10 20	50	M10	20	50	9,54 TL
PYck 50 10 30	50	M10	30	50	9,98 TL
PYck 50 10 40	50	M10	40	50	10,59 TL
PYck 50 10 50	50	M10	50	50	10,85 TL
PYck 63 10 20	63	M10	20	25	11,46 TL
PYck 63 10 30	63	M10	30	25	11,90 TL
PYck 63 10 40	63	M10	40	25	12,51 TL
PYck 63 10 50	63	M10	50	25	12,78 TL
PYck 63 12 40	63	M12	40	25	12,95 TL
PYck 63 16 50	63	M16	50	25	16,80 TL

PYBP PLASTİK YONCA BURÇLU PİRİNÇ

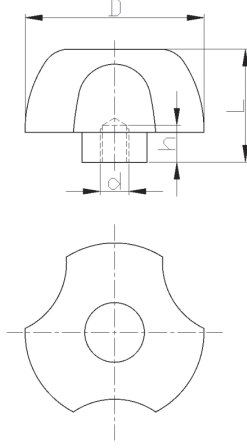

■ RAL 7021 Siyah

Ürün kodu	D	d	h	Pkt	Fiyat
PYBP 40 06	40	M06	10	100	8,49 TL
PYBP 40 08	40	M08	14	100	8,93 TL
PYBP 40 10	40	M10	17	100	9,80 TL
PYBP 50 08	50	M08	14	50	9,80 TL
PYBP 50 10	50	M10	17	50	11,03 TL
PYBP 63 10	63	M10	17	25	14,53 TL
PYBP 63 12	63	M12	19	25	17,50 TL
PYBP 63 16	63	M16	27	25	26,95 TL

PYCP PLASTİK YONCA CİVATALI PİRİNÇ

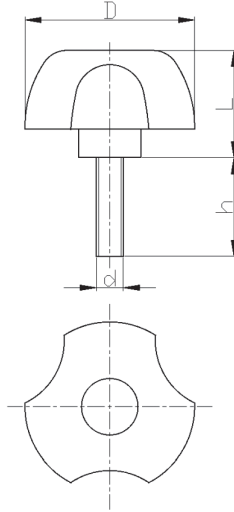

■ RAL 7021 Siyah

Ürün kodu	D	d	h	Pkt	Fiyat
PYCP 40 06 15	40	M06	15	100	10,24 TL
PYCP 40 06 20	40	M06	20	100	11,15 TL
PYCP 40 06 30	40	M06	30	100	12,97 TL
PYCP 40 06 40	40	M06	40	100	14,79 TL
PYCP 40 08 20	40	M08	20	100	11,15 TL
PYCP 40 08 30	40	M08	30	100	13,65 TL
PYCP 40 08 40	40	M08	40	100	14,22 TL
PYCP 40 10 20	40	M10	20	100	15,70 TL
PYCP 40 10 30	40	M10	30	100	15,93 TL
PYCP 40 10 40	40	M10	40	100	16,61 TL
PYCP 40 10 50	40	M10	50	100	18,54 TL
PYCP 50 08 20	50	M08	20	50	12,29 TL
PYCP 50 08 30	50	M08	30	50	14,11 TL
PYCP 50 08 40	50	M08	40	50	14,79 TL
PYCP 50 10 20	50	M10	20	50	16,04 TL
PYCP 50 10 30	50	M10	30	50	16,38 TL
PYCP 50 10 40	50	M10	40	50	17,06 TL
PYCP 50 10 50	50	M10	50	50	19,11 TL
PYCP 63 10 20	63	M10	20	25	17,29 TL
PYCP 63 10 30	63	M10	30	25	17,52 TL
PYCP 63 10 40	63	M10	40	25	18,20 TL
PYCP 63 10 50	63	M10	50	25	20,13 TL
PYCP 63 12 40	63	M12	40	25	20,02 TL
PYCP 63 16 50	63	M16	50	25	55,97 TL

PYBPt PLASTİK YONCA BURÇLU PİRİNÇ / Turuncu

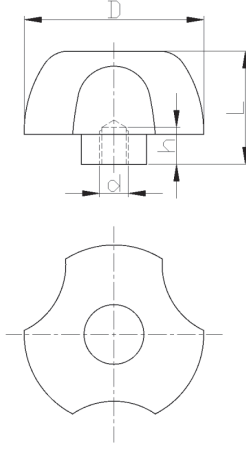

Ürün kodu	D	d	h	Pkt	Fiyat
PYBPt 40 06	40	M06	10	100	9,54 TL
PYBPt 40 08	40	M08	14	100	9,98 TL
PYBPt 40 10	40	M10	17	100	10,85 TL
PYBPt 50 08	50	M08	14	50	10,85 TL
PYBPt 50 10	50	M10	17	50	12,08 TL
PYBPt 63 10	63	M10	17	25	15,58 TL
PYBPt 63 12	63	M12	19	25	18,55 TL
PYBPt 63 16	63	M16	27	25	28,00 TL

PYCPt PLASTİK YONCA CİVATALI PİRİNÇ / Turuncu

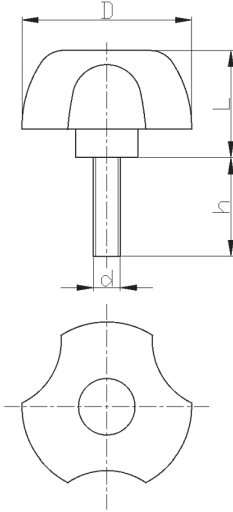

Ürün kodu	D	d	h	Pkt	Fiyat
PYCPt 40 06 15	40	M06	15	100	11,60 TL
PYCPt 40 06 20	40	M06	20	100	12,51 TL
PYCPt 40 06 30	40	M06	30	100	14,33 TL
PYCPt 40 06 40	40	M06	40	100	16,15 TL
PYCPt 40 08 20	40	M08	20	100	12,51 TL
PYCPt 40 08 30	40	M08	30	100	15,02 TL
PYCPt 40 08 40	40	M08	40	100	15,58 TL
PYCPt 40 10 20	40	M10	20	100	17,06 TL
PYCPt 40 10 30	40	M10	30	100	17,29 TL
PYCPt 40 10 40	40	M10	40	100	17,97 TL
PYCPt 40 10 50	40	M10	50	100	19,91 TL
PYCPt 50 08 20	50	M08	20	50	13,65 TL
PYCPt 50 08 30	50	M08	30	50	15,47 TL
PYCPt 50 08 40	50	M08	40	50	16,15 TL
PYCPt 50 10 20	50	M10	20	50	17,40 TL
PYCPt 50 10 30	50	M10	30	50	17,75 TL
PYCPt 50 10 40	50	M10	40	50	18,43 TL
PYCPt 50 10 50	50	M10	50	50	20,48 TL
PYCPt 63 10 20	63	M10	20	25	18,66 TL
PYCPt 63 10 30	63	M10	30	25	18,88 TL
PYCPt 63 10 40	63	M10	40	25	19,57 TL
PYCPt 63 10 50	63	M10	50	25	21,50 TL
PYCPt 63 12 40	63	M12	40	25	21,39 TL
PYCPt 63 16 50	63	M16	50	25	57,33 TL

■ RAL 2004 Turuncu

PYBPk PLASTİK YONCA BURÇLU PİRİNÇ / Kırmızı

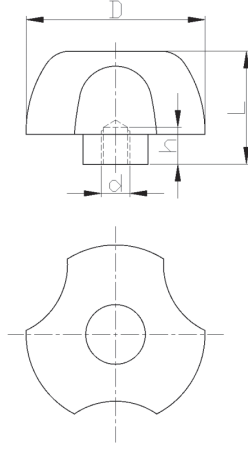

Ürün kodu	D	d	h	Pkt	Fiyat
PYBPk 40 06	40	M06	10	100	10,24 TL
PYBPk 40 08	40	M08	14	100	10,68 TL
PYBPk 40 10	40	M10	17	100	11,55 TL
PYBPk 50 08	50	M08	14	50	11,55 TL
PYBPk 50 10	50	M10	17	50	12,78 TL
PYBPk 63 10	63	M10	17	25	16,28 TL
PYBPk 63 12	63	M12	19	25	19,25 TL
PYBPk 63 16	63	M16	27	25	28,70 TL

■ RAL 3000 Kırmızı

PYCPk PLASTİK YONCA CİVATALI PİRİNÇ / Kırmızı

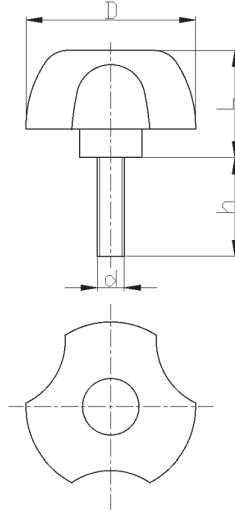
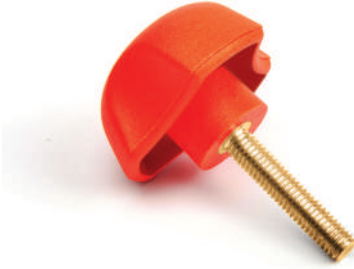

Ürün kodu	D	d	h	Pkt	Fiyat
PYCPk 40 06 15	40	M06	15	100	12,51 TL
PYCPk 40 06 20	40	M06	20	100	13,42 TL
PYCPk 40 06 30	40	M06	30	100	15,24 TL
PYCPk 40 06 40	40	M06	40	100	17,06 TL
PYCPk 40 08 20	40	M08	20	100	13,42 TL
PYCPk 40 08 30	40	M08	30	100	15,93 TL
PYCPk 40 08 40	40	M08	40	100	16,49 TL
PYCPk 40 10 20	40	M10	20	100	17,97 TL
PYCPk 40 10 30	40	M10	30	100	18,20 TL
PYCPk 40 10 40	40	M10	40	100	18,88 TL
PYCPk 40 10 50	40	M10	50	100	20,82 TL
PYCPk 50 08 20	50	M08	20	50	14,56 TL
PYCPk 50 08 30	50	M08	30	50	16,38 TL
PYCPk 50 08 40	50	M08	40	50	17,06 TL
PYCPk 50 10 20	50	M10	20	50	18,31 TL
PYCPk 50 10 30	50	M10	30	50	18,66 TL
PYCPk 50 10 40	50	M10	40	50	19,34 TL
PYCPk 50 10 50	50	M10	50	50	21,39 TL
PYCPk 63 10 20	63	M10	20	25	19,57 TL
PYCPk 63 10 30	63	M10	30	25	19,79 TL
PYCPk 63 10 40	63	M10	40	25	20,48 TL
PYCPk 63 10 50	63	M10	50	25	22,41 TL
PYCPk 63 12 40	63	M12	40	25	22,30 TL
PYCPk 63 16 50	63	M16	50	25	58,24 TL

■ RAL 3000 Kırmızı

PTB6 PLASTİK TUTAMAK BURÇLU 6



YENİ ÜRÜN

Ürün kodu	D	d	h	L	Pkt	Fiyat
PTB6 30 06	30	M6	10	22	100	2,90 TL
PTB6 30 08	30	M8	14	22	100	3,00 TL
PTB6 40 06	40	M6	10	24	100	3,20 TL
PTB6 40 08	40	M8	14	24	100	3,30 TL
PTB6 40 10	40	M10	15	24	100	3,40 TL

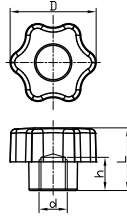

PTC6 PLASTİK TUTAMAK CİVATALI 6



YENİ ÜRÜN

Ürün kodu	D	d	h	L	Pkt	Fiyat
PTC6 30 06 15	30	M6	15	22	100	4,15 TL
PTC6 30 06 20	30	M6	20	22	100	4,20 TL
PTC6 30 06 30	30	M6	30	22	100	4,50 TL
PTC6 30 06 40	30	M6	40	22	100	4,80 TL
PTC6 30 08 20	30	M8	20	22	100	4,30 TL
PTC6 30 08 30	30	M8	30	22	100	4,50 TL
PTC6 30 08 40	30	M8	40	22	100	5,15 TL
PTC6 40 06 15	40	M6	15	24	100	4,45 TL
PTC6 40 06 20	40	M6	20	24	100	4,50 TL
PTC6 40 06 30	40	M6	30	24	100	4,80 TL
PTC6 40 06 40	40	M6	40	24	100	5,10 TL
PTC6 40 08 20	40	M8	20	24	100	4,60 TL
PTC6 40 08 30	40	M8	30	24	100	4,80 TL
PTC6 40 08 40	40	M8	40	24	100	5,45 TL
PTC6 40 10 20	40	M10	20	24	100	4,90 TL
PTC6 40 10 30	40	M10	30	24	100	5,10 TL
PTC6 40 10 40	40	M10	40	24	100	5,75 TL
PTC6 40 10 50	40	M10	50	24	100	6,05 TL

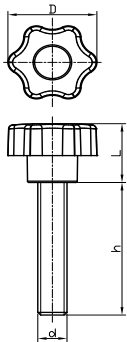

PTB4 PLASTİK TUTAMAK BURÇLU 4



YENİ ÜRÜN

Ürün kodu	D	d	h	L	Pkt	Fiyat
PTB4 30 06	30	M6	10	24	100	2,95 TL
PTB4 30 08	30	M8	14	24	100	3,05 TL
PTB4 60 08	60	M8	14	34	25	4,30 TL
PTB4 60 10	60	M10	17	34	25	4,50 TL
PTB4 60 12	60	M12	19	34	25	4,80 TL

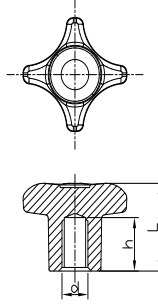

PTC4 PLASTİK TUTAMAK CİVATALI 4



YENİ ÜRÜN

Ürün kodu	D	d	h	L	Pkt	Fiyat
PTC4 30 06 15	30	M6	15	24	100	4,15 TL
PTC4 30 06 20	30	M6	20	24	100	4,20 TL
PTC4 30 06 30	30	M6	30	24	100	4,50 TL
PTC4 30 06 40	30	M6	40	24	100	4,80 TL
PTC4 30 08 20	30	M8	20	24	100	4,30 TL
PTC4 30 08 30	30	M8	30	24	100	4,50 TL
PTC4 30 08 40	30	M8	40	24	100	5,15 TL
PTC4 60 08 20	60	M8	20	34	25	5,10 TL
PTC4 60 08 30	60	M8	30	34	25	5,30 TL
PTC4 60 08 40	60	M8	40	34	25	5,95 TL
PTC4 60 10 20	60	M10	20	34	25	5,40 TL
PTC4 60 10 30	60	M10	30	34	25	5,60 TL
PTC4 60 10 40	60	M10	40	34	25	6,25 TL
PTC4 60 10 50	60	M10	50	34	25	6,55 TL
PTC4 60 12 40	60	M12	40	34	25	7,00 TL

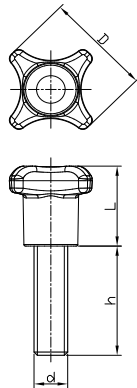

BKB BAKALİT KELEBEK BURÇLU

Açıklama
RAL 9005 Parlak Siyah
Çinko Kaplamalı Burç/ Demir Cıvata
Yağlara Greslere ve Solventlere Dayanıklı
-30°C / +120°C

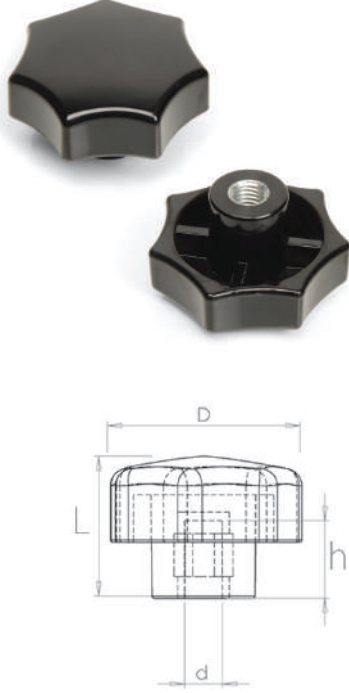

Ürün kodu	D	d	h	L	Pkt	Fiyat
BKB 20 05 11	20	M5	11	15	100	1,58 TL
BKB 20 06 11	20	M6	11	15	100	1,60 TL
BKB 30 06 11	30	M6	11	27	100	1,77 TL
BKB 30 08 15	30	M8	15	27	100	1,93 TL
BKB 40 06 11	40	M6	11	28	50	2,08 TL
BKB 40 08 15	40	M8	15	28	50	2,32 TL
BKB 40 08 20	40	M8	20	28	50	2,32 TL
BKB 40 10 17	40	M10	17	28	50	2,82 TL
BKB 50 08 15	50	M8	15	32	50	3,30 TL
BKB 50 10 17	50	M10	17	32	50	3,81 TL
BKB 63 08 15	63	M8	15	37	50	4,29 TL
BKB 63 10 17	63	M10	17	37	50	4,53 TL
BKB 63 12 22	63	M12	22	37	50	5,03 TL
BKB 70 10 17	70	M10	17	40	50	5,64 TL
BKB 70 12 22	70	M12	22	40	50	5,88 TL

BKC BAKALİT KELEBEK CİVATALI

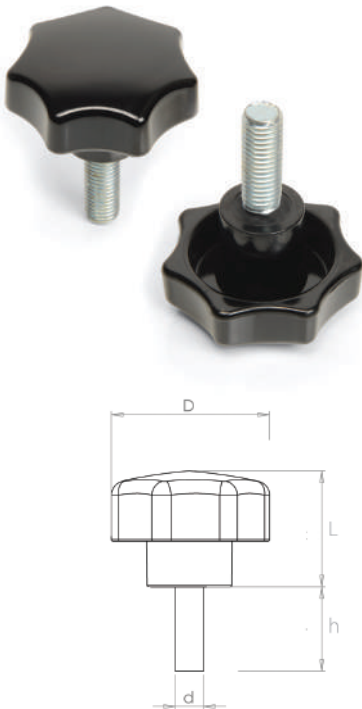

Ürün kodu	D	d	h	L	Pkt	Fiyat
BKC 20 05 13	20	M5	13	15	100	1,36 TL
BKC 20 06 10	20	M6	10	15	100	1,36 TL
BKC 30 06 15	30	M6	15	27	100	1,51 TL
BKC 30 08 15	30	M8	15	27	100	1,66 TL
BKC 40 06 15	40	M6	15	28	50	1,84 TL
BKC 40 06 20	40	M6	20	28	50	1,84 TL
BKC 40 08 15	40	M8	20	28	50	2,03 TL
BKC 40 08 20	40	M8	15	28	50	2,03 TL
BKC 40 08 50	40	M8	50	28	50	2,69 TL
BKC 40 10 20	40	M10	20	28	50	2,21 TL
BKC 50 08 25	50	M8	25	32	50	3,06 TL
BKC 50 10 25	50	M10	25	32	50	3,19 TL
BKC 50 10 30	50	M10	30	32	50	3,19 TL
BKC 63 08 25	63	M8	25	37	50	3,92 TL
BKC 63 10 30	63	M10	30	37	50	4,29 TL
BKC 63 12 30	63	M12	30	37	50	4,53 TL
BKC 63 12 35	63	M12	35	37	50	4,53 TL
BKC 70 10 35	70	M10	35	40	50	5,64 TL
BKC 70 12 35	70	M12	35	40	50	6,13 TL

Talep edildiğinde özel civata boylarında çalışılmaktadır.

BYB BAKALİT YAPRAK BURÇLU

Açıklama
RAL 9005 Parlak Siyah
Çinko Kaplamalı Burç/ Demir Civata
Yağlara Greslere Ve Solventlere Dayanıklı
-30°C / +120°C

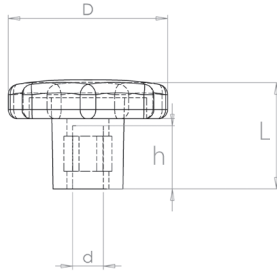

Ürün kodu	D	d	h	L	Pkt	Fiyat
BYB 30 06 11	30	M6	11	20	100	1,90 TL
BYB 30 08 15	30	M8	15	20	100	2,10 TL
BYB 40 06 11	40	M6	11	25	100	2,21 TL
BYB 40 08 15	40	M8	15	25	100	2,45 TL
BYB 40 10 17	40	M10	17	25	100	2,93 TL
BYB 50 08 15	50	M8	15	32	50	3,54 TL
BYB 50 10 17	50	M10	17	32	50	4,05 TL
BYB 63 08 15	63	M8	15	42	50	4,42 TL
BYB 63 10 17	63	M10	17	42	50	4,66 TL
BYB 63 12 22	63	M12	22	42	50	5,27 TL

BYC BAKALİT YAPRAK CİVATALI

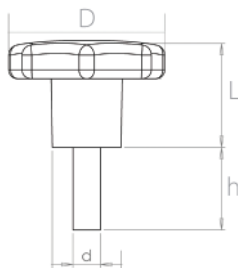

Ürün kodu	D	d	h	L	Pkt	Fiyat
BYC 30 06 15	30	M6	15	20	100	1,60 TL
BYC 30 06 25	30	M6	25	20	100	1,84 TL
BYC 30 08 15	30	M8	15	20	100	1,71 TL
BYC 40 06 20	40	M6	20	25	100	1,90 TL
BYC 40 08 20	40	M8	20	25	100	2,08 TL
BYC 40 10 20	40	M10	20	25	100	2,21 TL
BYC 50 08 25	50	M8	25	32	50	3,19 TL
BYC 50 10 25	50	M10	25	32	50	3,30 TL
BYC 63 08 25	63	M8	25	42	50	4,16 TL
BYC 63 10 30	63	M10	30	42	50	4,42 TL
BYC 63 12 30	63	M12	30	42	50	4,66 TL

BTB BAKALİT TOPUZ BURÇLU

Açıklama
RAL 9005 Parlak Siyah
Çinko Kaplamalı Burç/ Demir Civata
Yağlara Greslere ve Solventlere Dayanıklı
-30°C / +120°C

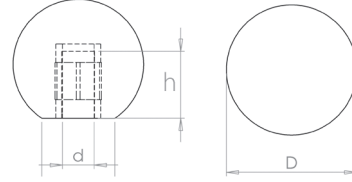

Ürün kodu	D	d	h	Pkt	Fiyat
BTB 25 05 11	25	M5	11	100	1,47 TL
BTB 25 06 11	25	M6	11	100	1,47 TL
BTB 25 08 15	25	M8	15	100	1,60 TL
BTB 30 06 11	30	M6	11	100	1,88 TL
BTB 30 08 15	30	M8	15	100	2,08 TL
BTB 30 10 17	30	M10	17	100	2,45 TL
BTB 35 08 15	35	M8	15	50	2,69 TL
BTB 35 10 17	35	M10	17	50	3,06 TL
BTB 40 08 15	40	M8	15	50	3,06 TL
BTB 40 10 17	40	M10	17	50	3,43 TL
BTB 40 12 22	40	M12	22	50	3,68 TL

**BSDC** BAKALİT SİLİNDİR DÖNERLİ CİVATALI

Ürün kodu	D	d	h	L	Pkt	Fiyat
BSDC 21 06 15	21	M6	15	50	25	10,78 TL
BSDC 23 08 15	23	M8	15	65	25	12,73 TL
BSDC 26 10 15	26	M10	15	80	25	14,70 TL
BSDC 28 12 15	28	M12	15	90	25	17,15 TL



BSB BAKALİT SİLİNDİR BURÇLU

Açıklama
RAL 9005 Parlak Siyah
Çinko Kaplamalı Burç/ Demir Civata
Yağlara Greslere ve Solventlere Dayanıklı
-30°C / +120°C



Ürün kodu	D	d	h	L	Pkt	Fiyat
BSB 18 06 11	18	M6	11	40	50	2,45 TL
BSB 21 08 15	21	M8	15	51	50	2,69 TL
BSB 21 10 17	21	M10	17	51	50	3,50 TL
BSB 23 08 15	23	M8	15	66	50	3,50 TL
BSB 23 10 17	23	M10	17	66	50	3,92 TL
BSB 26 10 17	26	M10	17	80	50	4,46 TL
BSB 26 12 22	26	M12	22	80	50	4,77 TL
BSB 28 10 17	28	M10	17	90	25	5,27 TL
BSB 28 12 22	28	M12	22	90	25	5,64 TL

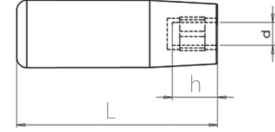

BSC BAKALİT SİLİNDİR CİVATALI



Ürün kodu	D	d	h	L	Pkt	Fiyat
BSC 18 06 15	18	M6	15	40	50	2,25 TL
BSC 21 08 15	21	M8	15	51	50	2,69 TL
BSC 21 10 15	21	M10	15	51	50	2,82 TL
BSC 23 08 20	23	M8	20	66	50	3,19 TL
BSC 23 10 20	23	M10	20	66	50	3,54 TL
BSC 26 10 25	26	M10	25	80	50	3,92 TL
BSC 26 12 25	26	M12	25	80	50	4,53 TL
BSC 28 10 25	28	M10	25	91	25	4,66 TL
BSC 28 12 25	28	M12	25	91	25	5,38 TL



BTVB BAKALİT TIRNAKLI VOLANT BURÇLU

Açıklama
RAL 9005 Parlak Siyah
Çinko Kaplamalı Burç/ Demir Civata
Yağlara Greslere ve Solventlere Dayanıklı
-30°C / +120°C



Ürün kodu	D	d	h	L	Pkt	Fiyat
BTVB 45 08 20	45	M8	20	30	10	11,88 TL
BTVB 45 10 20	45	M10	20	30	10	11,88 TL
BTVB 65 10 25	65	M10	25	27	10	14,70 TL
BTVB 65 12 25	65	M12	25	27	10	14,70 TL
BTVB 80 16 40	80	M16	40	50	5	20,21 TL
BTVB 10 20 40	10	M20	40	60	5	24,50 TL

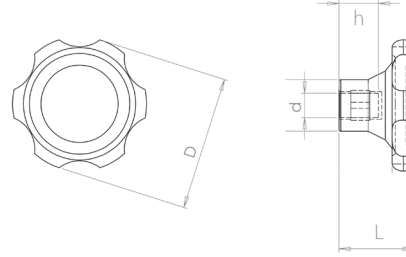

BTVC BAKALİT TIRNAKLI VOLANT CİVATALI



Ürün kodu	D	d	h	Pkt	Fiyat
BTVC 45 10 50	45	10	50	10	8,58 TL
BTVC 45 10 60	45	10	60	10	9,19 TL
BTVC 45 12 50	45	12	50	10	9,80 TL
BTVC 45 12 60	45	12	60	10	10,78 TL
BTVC 65 12 60	65	M12	60	10	15,44 TL
BTVC 80 16 50	80	M16	50	5	19,60 TL
BTVC 80 16 60	80	M16	60	5	20,83 TL

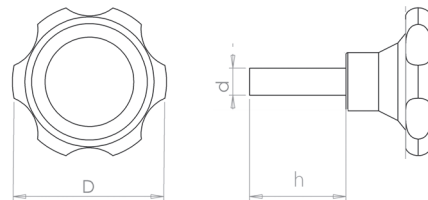

BTV BAKALİT TIRNAKLI VOLANT

Açıklama
RAL 9005 Parlak Siyah
Çinko Kaplamalı Burç/ Demir Civata
Yağlara Greslere ve Solventlere Dayanıklı
-30°C / +120°C



Ürün kodu	D	d	L	Pkt	Fiyat
BTV 45 20 11	45	20	33	10	9,84 TL
BTV 65 25 22	65	25	46	10	14,22 TL
BTV 80 30 25	80	30	50	5	19,69 TL
BTV 10 35 25	100	35	59	5	29,53 TL

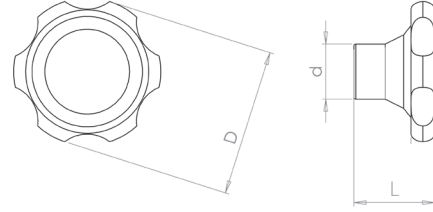

BTVBb BAKALİT TIRNAKLI VOLANT BURÇLU Boş

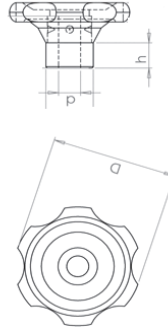

Ürün kodu	D	d	h	Pkt	Fiyat
BTVBb 45 08 15	45	8	15	10	11,03 TL
BTVBb 45 10 15	45	10	15	10	11,03 TL
BTVBb 45 12 15	45	12	15	10	11,03 TL
BTVBb 65 10 20	65	10	20	10	13,52 TL
BTVBb 65 10 25	65	10	25	10	13,52 TL
BTVBb 65 12 20	65	12	20	10	13,52 TL
BTVBb 65 12 25	65	12	25	10	13,52 TL
BTVBb 80 10 25	80	10	25	5	16,91 TL
BTVBb 80 12 25	80	12	25	5	16,91 TL
BTVBb 80 14 25	80	14	25	5	17,15 TL
BTVBb 80 16 25	80	16	25	5	17,15 TL
BTVBb 10 16 30	100	16	30	5	24,50 TL
BTVBb 10 20 30	100	20	30	5	24,50 TL

BDV BAKALİT DOLU VOLANT



Ürün kodu	D	d1	l1	d2	Pkt	Fiyat
BDV 10 24 14	100	24	14	M6	6	18,38 TL
BDV 12 32 15	125	32	15	M8	4	22,05 TL
BDV 15 32 15	150	32	15	M8	4	29,40 TL
BDV 17 40 15	175	40	15	M10	2	36,75 TL
BDV 20 40 15	200	40	15	M12	2	53,90 TL

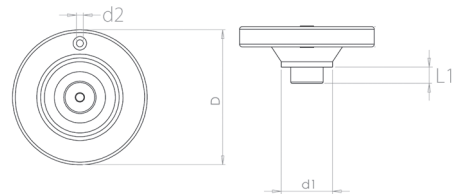

BKV BAKALİT KOLLU VOLANT



Açıklama
RAL 9005 Parlak Siyah
Çinko Kaplamalı Burç/ Demir Civata
Yağlara Greslere ve Solventlere Dayanıklı
-30°C / +120°C

Ürün kodu	D	d1	l1	d2	Pkt	Fiyat
BKV 10 30 12	100	30	12	M6	6	17,15 TL
BKV 12 40 12	125	40	12	M6	4	22,05 TL
BKV 15 50 15	150	50	15	M8	4	35,53 TL
BKV 17 50 18	175	50	18	M10	2	53,90 TL
BKV 20 50 18	200	50	18	M12	2	56,35 TL

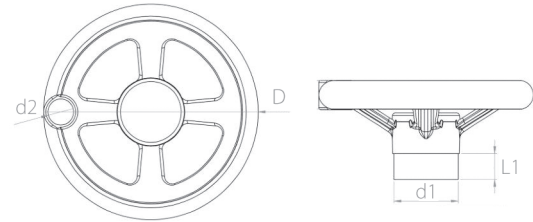

BT BAKALİT TUTAMAK



Ürün kodu	L	l1	d	Pkt	Fiyat
BT 13 06 11	132	109	M6	25	12,03 TL
BT 16 08 15	165	131	M8	25	15,31 TL
BT 16 10 17	165	131	M10	25	15,31 TL

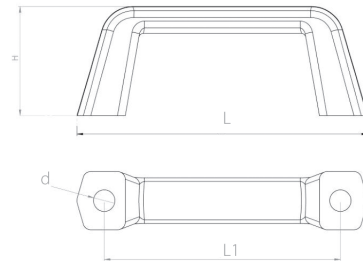

AT ALÜMİNYUM TUTAMAK



Ürün kodu	l1	L	B	d	H	Pkt	Fiyat
AT 200 20	200	230	20	M8	57	10	12,60 TL
AT 300 20	300	330	20	M8	57	10	14,70 TL
AT 400 20	400	430	20	M8	57	10	16,80 TL
AT 500 20	500	530	20	M8	57	10	18,90 TL
AT 600 20	600	630	20	M8	57	10	21,35 TL
AT -20	50	20	M8	57	10	4,71 TL	

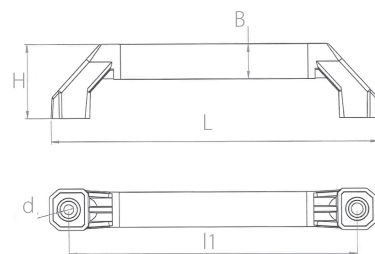

MTs METAL TUTAMAK SİYAH



YENİ ÜRÜN

Ürün kodu	l1	L	B	d	H	Pkt
MTs 200 30	200	230	30	m8	57	10
MTs 300 30	300	330	30	m8	57	10
MTs 400 30	400	430	30	m8	57	10
MTs 500 30	500	530	30	m8	57	10
MTs 600 30	600	630	30	m8	57	10

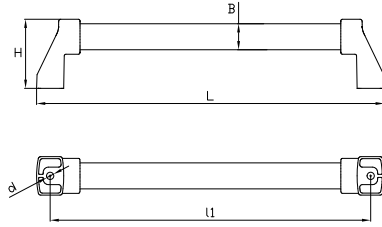

MTk METAL TUTAMAK KROM



YENİ ÜRÜN

Ürün kodu	l1	L	B	d	H	Pkt
MTk 200 30	200	230	30	m8	57	10
MTk 300 30	300	330	30	m8	57	10
MTk 400 30	400	430	30	m8	57	10
MTk 500 30	500	530	30	m8	57	10
MTk 600 30	600	630	30	m8	57	10

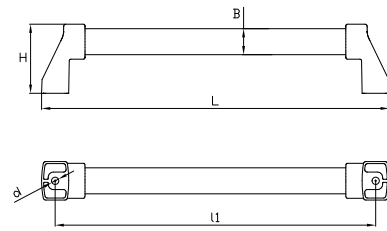

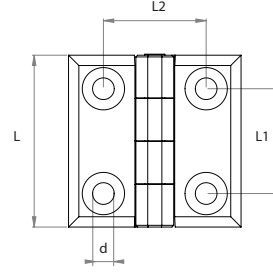
PM PLASTİK MENTEŞE

Ürün kodu	L1xL2	d	Pkt	Fiyat
PM 40X40	25x25	5,5	50	4,64 TL
PM 48X48	30x30	5,5	50	5,69 TL
PM 50X50	30x30	6,5	50	5,69 TL
PM 75X65	72x45	6,5	50	11,27 TL
PM 100X80	72x45	8,5	50	12,88 TL

ZMb ZAMAK MENTEŞE BOYALI

Ürün kodu	L1xL2	d	Pkt	Fiyat
ZMb 40X40	25x25	5,5	25	7,26 TL
ZMb 50X50	30x30	6,5	25	10,76 TL
ZMb 50X63	30x43	6,5	25	15,58 TL
ZMb 50X76	30x56	6,5	25	15,58 TL
ZMb 60X60	36x36	8	25	21,88 TL

ZMk ZAMAK MENTEŞE KROM

Ürün kodu	L1xL2	d	Pkt	Fiyat
ZMk 40X40	25x25	5,5	25	7,26 TL
ZMk 50X50	30x30	6,5	25	10,76 TL
ZMk 50X63	30x43	6,5	25	15,58 TL
ZMk 50X76	30x56	6,5	25	15,58 TL
ZMk 60X60	36x36	8	25	21,88 TL

ZMCK ZAMAK MENTEŞE CİVATALI KROM

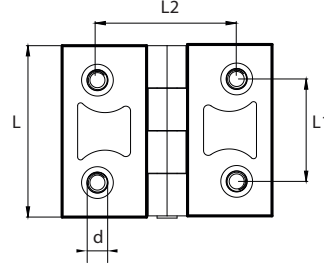

Ürün kodu	L1xL2	d	Pkt	Fiyat
ZMCK 40X40	25x25	M5x9	25	9,10 TL
ZMCK 50X50	30x30	M6x12	25	13,65 TL
ZMCK 50X63	30x43	M6x12	25	17,59 TL
ZMCK 50X76	30x56	M6x12	25	17,59 TL
ZMCK 60X60	36x36	M8x14	25	24,41 TL

PMC PLASTİK MENTEŞE CİVATALI



Ürün kodu	L1xL2	d	Pkt	Fiyat
PMC 40X40	25x25	M5x9	50	6,30 TL
PMC 48X48	30x30	M5x12	50	7,00 TL
PMC 50X50	30x30	M6x11	50	7,00 TL

ZMCb ZAMAK MENTEŞE CİVATALI BOYALI



Ürün kodu	L1xL2	d	Pkt	Fiyat
ZMCb 40X40	25x25	M5x9	25	9,10 TL
ZMCb 50X50	30x30	M6x12	25	13,65 TL
ZMCb 50X63	30x43	M6x12	25	17,59 TL
ZMCb 50X76	30x56	M6x12	25	17,59 TL
ZMCb 60x60	36x36	M8x14	25	24,41 TL

SMB SAC MENTEŞE BOYALI

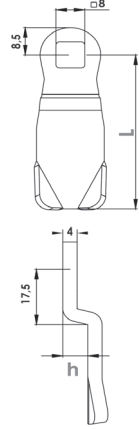

Ürün kodu	L1xL2	d	Pkt	Fiyat
SMB 60X76 4 Delikli	36x50	8,30	25	16,63 TL
SMB 60X106 5 Delikli	36x80	8,30	25	18,38 TL
SMB 60X136 6 Delikli	36x110	8,30	25	20,13 TL

YPKk YAYLI PANO KİLİDİ KROM (Kelebek)

Ürün kodu	h	L	Pkt	Fiyat
YPKk 1.0.50	0	50	25	14,00 TL
YPKk 1.5.48	5	48	25	14,00 TL
YPKk 1.7.48	7	48	25	14,00 TL

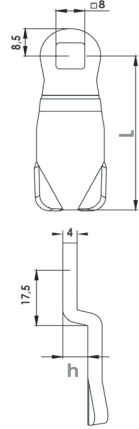
YPKb YAYLI PANO KİLİDİ BOYALI (Kelebek)

Ürün kodu	h	L	Pkt	Fiyat
YPKb 1.0.50	0	50	25z	14,00 TL
YPKb 1.5.48	5	48	25	14,00 TL
YPKb 1.7.48	7	48	25	14,00 TL

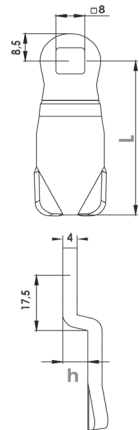
YPKp YAYLI PANO KİLİDİ PLASTİK (Kelebek)

Ürün kodu	h	L	Pkt	Fiyat
YPKp 1.0.50	0	50	25	7,00 TL
YPKp 1.5.48	5	48	25	7,00 TL
YPKp 1.7.48	7	48	25	7,00 TL

YPK2 YAYLI PANO KİLİDİ DB (Göbekli)

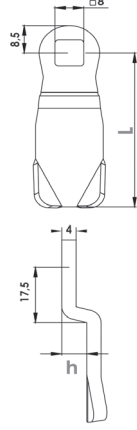

Ürün kodu	h	L	Pkt	Fiyat
YPK 2.0.50	0	50	25	11,55 TL
YPK 2.5.48	5	48	25	11,55 TL
YPK 2.7.48	7	48	25	11,55 TL

YPK3 YAYLI PANO KİLİDİ ÜÇGEN (Göbekli)

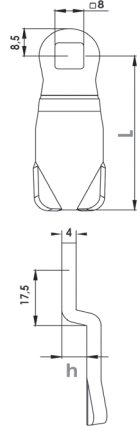

Ürün kodu	h	L	Pkt	Fiyat
YPK 3.0.50	0	50	25	11,55 TL
YPK 3.5.48	5	48	25	11,55 TL
YPK 3.7.48	7	48	25	11,55 TL

YPK4 YAYLI PANO KİLİDİ KARE (Göbekli)

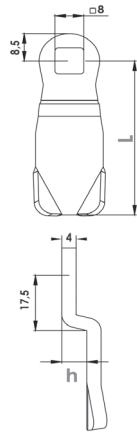

Ürün kodu	h	L	Pkt	Fiyat
YPK 4.0.50	0	50	25	11,55 TL
YPK 4.5.48	5	48	25	11,55 TL
YPK 4.7.48	7	48	25	11,55 TL

ANAHTAR



Ürün kodu	Pkt	Fiyat
A 2.5mm DB	25	4,81 TL
A 3.9mm ÜÇGEN	25	4,81 TL
A 4.8mm KARE	25	4,81 TL

TCBp CİVATALI BURÇLU TAKOZ/ Pullu

Malzeme Doğal Kauçuk
Metal Çinko Kaplı
Sertlik 70 ±5 Shore
Sıcaklık Direnci -20°C/+ 80°C

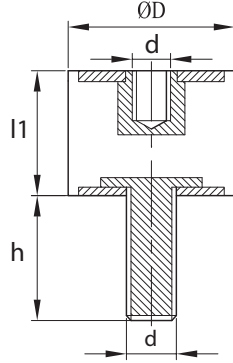

Ürün kodu	D	l1	d	h	Pkt	Fiyat
TCBp 5045	50	45	M 10	28	25	13,68 TL
TCBp 5050	50	50	M 10	28	25	13,98 TL
TCBp 6025	60	25	M 12	32	25	14,69 TL
TCBp 6030	60	30	M 12	32	25	15,72 TL
TCBp 6035	60	35	M 12	32	25	16,44 TL
TCBp 6040	60	40	M 12	32	25	18,33 TL
TCBp 7035	70	35	M 12	37	25	22,37 TL
TCBp 7040	70	40	M 12	37	25	23,00 TL
TCBp 7045	70	45	M 12	37	25	23,00 TL
TCBp 7525	75	25	M 12	37	25	20,96 TL
TCBp 7530	75	30	M 12	37	25	22,07 TL
TCBp 7540	75	40	M 12	37	25	25,38 TL
TCBp 7545	75	45	M 12	37	25	27,95 TL
TCBp 7550	75	50	M 12	37	25	32,13 TL
TCBp 7555	75	55	M 12	37	25	32,13 TL
TCBp 7570	75	70	M 12	37	25	37,06 TL
TCBp 10030	100	30	M 16	42	25	49,39 TL
TCBp 10040	100	40	M 16	42	25	60,88 TL
TCBp 10050	100	50	M 16	42	25	60,88 TL
TCBp 10055	100	55	M 16	42	25	60,88 TL
TCBp 10060	100	60	M 16	42	25	66,83 TL
TCBp 10075	100	75	M 16	42	25	96,85 TL
TCBp 12540	125	40	M 16	42	25	116,22 TL
TCBp 15045	150	45	M 20	42	25	143,89 TL
TCBp 15050	150	50	M 20	42	25	149,43 TL
TCBp 15055	150	55	M 20	42	25	154,96 TL
TCBp 15060	150	60	M 20	42	25	166,03 TL

Ürün kodu	D	l1	d	h	Pkt	Fiyat
TCBp 1010	10	10	M 4	10	25	3,33 TL
TCBp 1508	15	8	M 4	10	25	3,48 TL
TCBp 1510	15	10	M 4	10	25	3,48 TL
TCBp 1515	15	15	M 4	10	25	3,51 TL
TCBp 1520	15	20	M 4	10	25	3,51 TL
TCBp 2008	20	8	M 6	15	25	3,51 TL
TCBp 2010	20	10	M 6	15	25	3,51 TL
TCBp 2015	20	15	M 6	15	25	3,83 TL
TCBp 2020	20	20	M 6	15	25	4,14 TL
TCBp 2025	20	25	M 6	15	25	4,46 TL
TCBp 2030	20	30	M 6	15	25	4,46 TL
TCBp 2508	25	8	M 6	18	25	4,46 TL
TCBp 2510	25	10	M 6	18	25	4,46 TL
TCBp 2515	25	15	M 6	18	25	4,46 TL
TCBp 2517	25	17	M 6	18	25	4,46 TL
TCBp 2520	25	20	M 6	18	25	4,46 TL
TCBp 2523	25	23	M 6	18	25	4,46 TL
TCBp 2525	25	25	M 6	18	25	4,46 TL
TCBp 2530	25	30	M 6	18	25	4,68 TL
TCBp 3015	30	15	M 8	20	25	5,05 TL
TCBp 3017	30	17	M 8	20	25	5,53 TL
TCBp 3020	30	20	M 8	20	25	5,53 TL
TCBp 3025	30	25	M 8	20	25	6,02 TL
TCBp 3028	30	28	M 8	20	25	6,23 TL
TCBp 3030	30	30	M 8	20	25	6,54 TL
TCBp 3040	30	40	M 8	20	25	7,19 TL
TCBp 3535	35	35	M 8	20	25	7,19 TL
TCBp 4020	40	20	M 8	20	25	7,19 TL
TCBp 4025	40	25	M 8	20	25	7,63 TL
TCBp 4027	40	27	M 8	20	25	8,13 TL
TCBp 4028	40	28	M 8	20	25	8,13 TL
TCBp 4030	40	30	M 8	20	25	8,53 TL
TCBp 4040	40	40	M 8	20	25	9,06 TL
TCBp 4525	45	25	M 8	20	25	9,79 TL
TCBp 4535	45	35	M 8	28	25	10,76 TL
TCBp 5020	50	20	M 10	28	25	10,76 TL
TCBp 5025	50	25	M 10	28	25	10,76 TL
TCBp 5030	50	30	M 10	28	25	11,51 TL
TCBp 5035	50	35	M 10	28	25	12,16 TL
TCBp 5040	50	40	M 10	28	25	13,21 TL
TCBp 5042	50	42	M 10	28	25	13,68 TL

TCCp ÇİFT CİVATALI TAKOZ/ Pullu

Malzeme Doğal Kauçuk
Metal Çinko Kaplı
Sertlik 70 ±5 Shore
Sıcaklık Direnci -20°C/+ 80°C

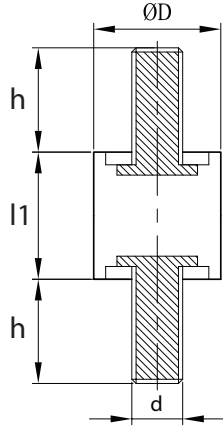

Ürün kodu	D	l1	d	h	Pkt	Fiyat
TCCp 5045	50	45	M 10	28	25	13,68 TL
TCCp 5050	50	50	M 10	28	25	13,98 TL
TCCp 6025	60	25	M 12	32	25	14,69 TL
TCCp 6030	60	30	M 12	32	25	15,72 TL
TCCp 6035	60	35	M 12	32	25	16,44 TL
TCCp 6040	60	40	M 12	32	25	17,47 TL
TCCp 7035	70	35	M 12	37	25	22,37 TL
TCCp 7040	70	40	M 12	37	25	23,00 TL
TCCp 7045	70	45	M 12	37	25	23,00 TL
TCCp 7525	75	25	M 12	37	25	20,96 TL
TCCp 7530	75	30	M 12	37	25	22,07 TL
TCCp 7540	75	40	M 12	37	25	25,38 TL
TCCp 7545	75	45	M 12	37	25	27,95 TL
TCCp 7550	75	50	M 12	37	25	30,73 TL
TCCp 7555	75	55	M 12	37	25	31,57 TL
TCCp 7570	75	70	M 12	37	25	37,06 TL
TCCp 10030	100	30	M 16	42	25	49,39 TL
TCCp 10040	100	40	M 16	42	25	55,34 TL
TCCp 10050	100	50	M 16	42	25	60,88 TL
TCCp 10055	100	55	M 16	42	25	60,88 TL
TCCp 10060	100	60	M 16	42	25	66,83 TL
TCCp 10075	100	75	M 16	42	25	96,85 TL
TCCp 12540	125	40	M 16	42	25	116,22 TL
TCCp 15045	150	45	M 20	42	25	143,89 TL
TCCp 15050	150	50	M 20	42	25	149,43 TL
TCCp 15055	150	55	M 20	42	25	154,96 TL
TCCp 15060	150	60	M 20	42	25	166,03 TL

Ürün kodu	D	l1	d	h	Pkt	Fiyat
TCCp 1010	10	10	M 4	10	25	3,18 TL
TCCp 1508	15	8	M 4	10	25	3,18 TL
TCCp 1510	15	10	M 4	10	25	3,18 TL
TCCp 1515	15	15	M 4	10	25	3,51 TL
TCCp 1520	15	20	M 4	10	25	3,51 TL
TCCp 2008	20	8	M 6	15	25	3,51 TL
TCCp 2010	20	10	M 6	15	25	3,51 TL
TCCp 2015	20	15	M 6	15	25	3,83 TL
TCCp 2020	20	20	M 6	15	25	4,14 TL
TCCp 2025	20	25	M 6	15	25	4,45 TL
TCCp 2030	20	30	M 6	15	25	4,45 TL
TCCp 2508	25	8	M 6	18	25	4,45 TL
TCCp 2510	25	10	M 6	18	25	4,45 TL
TCCp 2515	25	15	M 6	18	25	4,45 TL
TCCp 2517	25	17	M 6	18	25	4,45 TL
TCCp 2520	25	20	M 6	18	25	4,45 TL
TCCp 2523	25	23	M 6	18	25	4,45 TL
TCCp 2525	25	25	M 6	18	25	4,45 TL
TCCp 2530	25	30	M 6	18	25	4,45 TL
TCCp 3015	30	15	M 8	20	25	4,81 TL
TCCp 3017	30	17	M 8	20	25	5,27 TL
TCCp 3020	30	20	M 8	20	25	5,53 TL
TCCp 3025	30	25	M 8	20	25	5,73 TL
TCCp 3028	30	28	M 8	20	25	6,23 TL
TCCp 3030	30	30	M 8	20	25	6,23 TL
TCCp 3040	30	40	M 8	20	25	7,19 TL
TCCp 3535	35	35	M 8	20	25	7,19 TL
TCCp 4020	40	20	M 8	20	25	7,19 TL
TCCp 4025	40	25	M 8	20	25	7,63 TL
TCCp 4027	40	27	M 8	20	25	8,13 TL
TCCp 4028	40	28	M 8	20	25	8,13 TL
TCCp 4030	40	30	M 8	20	25	8,53 TL
TCCp 4040	40	40	M 8	20	25	8,64 TL
TCCp 4525	45	25	M 8	20	25	9,79 TL
TCCp 4535	45	35	M 8	28	25	10,28 TL
TCCp 5020	50	20	M 10	28	25	9,79 TL
TCCp 5025	50	25	M 10	28	25	10,48 TL
TCCp 5030	50	30	M 10	28	25	10,98 TL
TCCp 5035	50	35	M 10	28	25	11,59 TL
TCCp 5040	50	40	M 10	28	25	12,60 TL
TCCp 5042	50	42	M 10	28	25	13,68 TL

TBBP ÇİFT BURÇLU TAKOZ/ Pullu

Malzeme Doğal Kauçuk
Metal Çinko Kaplı
Sertlik 70 ±5 Shore
Sıcaklık Direnci -20°C/+ 80°C

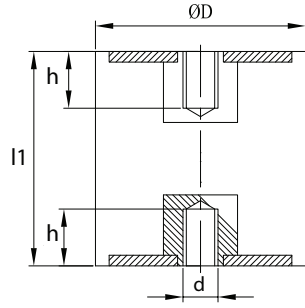

Ürün kodu	D	l1	d	h	Pkt	Fiyat
TBBp 7525	75	25	M 12	12	25	23,00 TL
TBBp 7530	75	30	M 12	12	25	23,00 TL
TBBp 7540	75	40	M 12	12	25	25,38 TL
TBBp 7545	75	45	M 12	12	25	27,95 TL
TBBp 7550	75	50	M 12	12	25	29,33 TL
TBBp 7555	75	55	M 12	12	25	33,08 TL
TBBp 7570	75	70	M 12	12	25	37,06 TL
TBBp 10030	100	30	M 16	16	25	49,40 TL
TBBp 10040	100	40	M 16	16	25	60,88 TL
TBBp 10050	100	50	M 16	16	25	60,88 TL
TBBp 10055	100	55	M 16	16	25	63,92 TL
TBBp 10060	100	60	M 16	16	25	70,00 TL
TBBp 10075	100	75	M 16	16	25	96,85 TL
TBBp 12540	125	40	M 16	16	25	116,22 TL
TBBp 15045	150	45	M 20	16	25	143,89 TL
TBBp 15050	150	50	M 20	16	25	149,43 TL
TBBp 15055	150	55	M 20	16	25	154,96 TL
TBBp 15060	150	60	M 20	16	25	166,03 TL

Ürün kodu	D	l1	d	h	Pkt	Fiyat
TBBp 1515	15	15	M 4	4	25	4,24 TL
TBBp 1520	15	20	M 4	4	25	4,24 TL
TBBp 2015	20	15	M 6	6	25	4,24 TL
TBBp 2020	20	20	M 6	6	25	4,55 TL
TBBp 2025	20	25	M 6	6	25	4,91 TL
TBBp 2030	20	30	M 6	6	25	4,91 TL
TBBp 2510	25	10	M 6	6	25	4,91 TL
TBBp 2515	25	15	M 6	6	25	4,91 TL
TBBp 2517	25	17	M 6	6	25	4,91 TL
TBBp 2520	25	20	M 6	6	25	4,91 TL
TBBp 2523	25	23	M 6	6	25	4,91 TL
TBBp 2525	25	25	M 6	6	25	5,14 TL
TBBp 2530	25	30	M 6	6	25	6,13 TL
TBBp 3020	30	20	M 8	8	25	6,13 TL
TBBp 3025	30	25	M 8	8	25	6,61 TL
TBBp 3028	30	28	M 8	8	25	6,86 TL
TBBp 3030	30	30	M 8	8	25	7,18 TL
TBBp 3040	30	40	M 8	8	25	7,91 TL
TBBp 3535	35	35	M 8	8	25	7,91 TL
TBBp 4020	40	20	M 8	8	25	7,91 TL
TBBp 4025	40	25	M 8	8	25	8,39 TL
TBBp 4027	40	27	M 8	8	25	8,95 TL
TBBp 4028	40	28	M 8	8	25	8,95 TL
TBBp 4030	40	30	M 8	8	25	8,95 TL
TBBp 4040	40	40	M 8	8	25	9,95 TL
TBBp 4525	45	25	M 8	8	25	9,79 TL
TBBp 4535	45	35	M 8	10	25	10,76 TL
TBBp 5025	50	25	M 10	10	25	10,98 TL
TBBp 5030	50	30	M 10	10	25	12,03 TL
TBBp 5035	50	35	M 10	10	25	12,16 TL
TBBp 5040	50	40	M 10	10	25	13,21 TL
TBBp 5042	50	42	M 10	10	25	13,68 TL
TBBp 5045	50	45	M 10	10	25	14,37 TL
TBBp 5050	50	50	M 10	10	25	14,66 TL
TBBp 6025	60	25	M 12	12	25	14,69 TL
TBBp 6030	60	30	M 12	12	25	15,72 TL
TBBp 6035	60	35	M 12	12	25	16,44 TL
TBBp 6040	60	40	M 12	12	25	18,33 TL
TBBp 7035	70	35	M 12	12	25	22,37 TL
TBBp 7040	70	40	M 12	12	25	23,00 TL
TBBp 7045	70	45	M 12	12	25	23,00 TL

TCp TEK CİVATALI TAKOZ/ Pullu

Malzeme Doğal Kauçuk
Metal Çinko Kaplı
Sertlik 70 ±5 Shore
Sıcaklık Direnci -20°C/+ 80°C

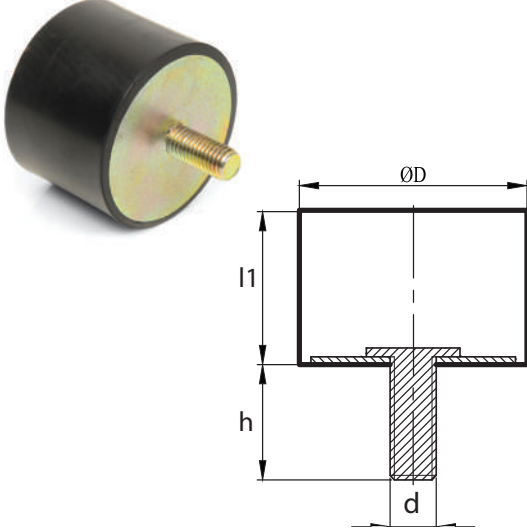

Ürün kodu	D	l1	d	h	Pkt	Fiyat
TCp 5045	50	45	M 10	28	25	12,04 TL
TCp 5050	50	50	M 10	28	25	13,00 TL
TCp 6025	60	25	M 12	32	25	13,23 TL
TCp 6030	60	30	M 12	32	25	13,48 TL
TCp 6035	60	35	M 12	32	25	14,63 TL
TCp 6040	60	40	M 12	32	25	15,88 TL
TCp 7035	70	35	M 12	37	25	18,32 TL
TCp 7040	70	40	M 12	37	25	18,82 TL
TCp 7045	70	45	M 12	37	25	18,82 TL
TCp 7525	75	25	M 12	37	25	18,82 TL
TCp 7530	75	30	M 12	37	25	18,82 TL
TCp 7540	75	40	M 12	37	25	20,96 TL
TCp 7545	75	45	M 12	37	25	23,08 TL
TCp 7550	75	50	M 12	37	25	25,00 TL
TCp 7555	75	55	M 12	37	25	25,01 TL
TCp 7570	75	70	M 12	37	25	38,50 TL
TCp 10030	100	30	M 16	42	25	41,40 TL
TCp 10040	100	40	M 16	42	25	48,43 TL
TCp 10050	100	50	M 16	42	25	51,03 TL
TCp 10055	100	55	M 16	42	25	53,41 TL
TCp 10060	100	60	M 16	42	25	55,90 TL
TCp 10075	100	75	M 16	42	25	77,00 TL
TCp 12540	125	40	M 16	42	25	91,44 TL
TCp 15045	150	45	M 20	42	25	120,31 TL
TCp 15050	150	50	M 20	42	25	131,38 TL
TCp 15055	150	55	M 20	42	25	136,43 TL
TCp 15060	150	60	M 20	42	25	156,19 TL

Ürün kodu	D	l1	d	h	Pkt	Fiyat
TCp 1010	10	10	M 4	10	25	2,87 TL
TCp 1508	15	8	M 4	10	25	2,87 TL
TCp 1510	15	10	M 4	10	25	2,86 TL
TCp 1515	15	15	M 4	10	25	3,18 TL
TCp 1520	15	20	M 4	10	25	3,33 TL
TCp 2008	20	8	M 6	15	25	3,33 TL
TCp 2010	20	10	M 6	15	25	3,51 TL
TCp 2015	20	15	M 6	15	25	3,51 TL
TCp 2020	20	20	M 6	15	25	3,66 TL
TCp 2025	20	25	M 6	15	25	3,83 TL
TCp 2030	20	30	M 6	15	25	3,97 TL
TCp 2508	25	8	M 6	18	25	4,13 TL
TCp 2510	25	10	M 6	18	25	4,13 TL
TCp 2515	25	15	M 6	18	25	4,14 TL
TCp 2517	25	17	M 6	18	25	4,14 TL
TCp 2520	25	20	M 6	18	25	4,14 TL
TCp 2523	25	23	M 6	18	25	4,46 TL
TCp 2525	25	25	M 6	18	25	4,46 TL
TCp 2530	25	30	M 6	18	25	4,46 TL
TCp 3015	30	15	M 8	20	25	4,46 TL
TCp 3017	30	17	M 8	20	25	4,59 TL
TCp 3020	30	20	M 8	20	25	4,60 TL
TCp 3025	30	25	M 8	20	25	5,22 TL
TCp 3028	30	28	M 8	20	25	5,60 TL
TCp 3030	30	30	M 8	20	25	5,61 TL
TCp 3040	30	40	M 8	20	25	6,34 TL
TCp 3535	35	35	M 8	20	25	6,34 TL
TCp 4020	40	20	M 8	20	25	6,35 TL
TCp 4025	40	25	M 8	20	25	7,00 TL
TCp 4027	40	27	M 8	20	25	7,31 TL
TCp 4028	40	28	M 8	20	25	7,31 TL
TCp 4030	40	30	M 8	20	25	7,32 TL
TCp 4040	40	40	M 8	20	25	7,63 TL
TCp 4525	45	25	M 8	28	25	8,73 TL
TCp 4535	45	35	M 8	28	25	8,73 TL
TCp 5020	50	20	M 10	28	25	8,73 TL
TCp 5025	50	25	M 10	28	25	8,73 TL
TCp 5030	50	30	M 10	28	25	9,16 TL
TCp 5035	50	35	M 10	28	25	10,14 TL
TCp 5040	50	40	M 10	28	25	11,14 TL
TCp 5042	50	42	M 10	28	25	12,06 TL

TBp TEK BURÇLU TAKOZ/ Pullu

Malzeme Doğal Kauçuk
Metal Çinko Kaplı
Sertlik 70 ±5 Shore
Sıcaklık Direnci -20°C/+ 80°C

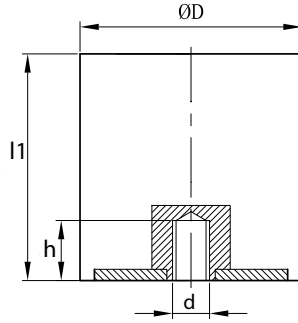

Ürün kodu	D	l1	d	h	Pkt	Fiyat
TBp 5045	50	45	M 10	10	25	12,06 TL
TBp 5050	50	50	M 10	10	25	13,00 TL
TBp 6025	60	25	M 12	12	25	13,23 TL
TBp 6030	60	30	M 12	12	25	14,13 TL
TBp 6035	60	35	M 12	12	25	14,63 TL
TBp 6040	60	40	M 12	12	25	16,67 TL
TBp 7035	70	35	M 12	12	25	18,32 TL
TBp 7040	70	40	M 12	12	25	18,82 TL
TBp 7045	70	45	M 12	12	25	18,82 TL
TBp 7525	75	25	M 12	12	25	18,82 TL
TBp 7530	75	30	M 12	12	25	18,82 TL
TBp 7540	75	40	M 12	12	25	20,96 TL
TBp 7545	75	45	M 12	12	25	23,08 TL
TBp 7550	75	50	M 12	12	25	25,27 TL
TBp 7555	75	55	M 12	12	25	26,25 TL
TBp 7570	75	70	M 12	12	25	42,35 TL
TBp 10030	100	30	M 16	16	25	42,35 TL
TBp 10040	100	40	M 16	16	25	50,73 TL
TBp 10050	100	50	M 16	16	25	56,13 TL
TBp 10055	100	55	M 16	16	25	58,76 TL
TBp 10060	100	60	M 16	16	25	61,47 TL
TBp 10075	100	75	M 16	16	25	77,00 TL
TBp 12540	125	40	M 16	16	25	91,44 TL
TBp 15045	150	45	M 20	16	25	126,33 TL
TBp 15050	150	50	M 20	16	25	131,38 TL
TBp 15055	150	55	M 20	16	25	137,81 TL
TBp 15060	150	60	M 20	16	25	156,65 TL

Ürün kodu	D	l1	d	h	Pkt	Fiyat
TBp 1010	10	10	M 4	4	25	2,87 TL
TBp 1508	15	8	M 4	4	25	2,87 TL
TBp 1510	15	10	M 4	4	25	3,00 TL
TBp 1515	15	15	M 4	4	25	3,18 TL
TBp 1520	15	20	M 4	4	25	3,33 TL
TBp 2008	20	8	M 6	6	25	3,33 TL
TBp 2010	20	10	M 6	6	25	3,51 TL
TBp 2015	20	15	M 6	6	25	3,51 TL
TBp 2020	20	20	M 6	6	25	3,66 TL
TBp 2025	20	25	M 6	6	25	3,83 TL
TBp 2030	20	30	M 6	6	25	3,97 TL
TBp 2508	25	8	M 6	6	25	4,13 TL
TBp 2510	25	10	M 6	6	25	4,13 TL
TBp 2515	25	15	M 6	6	25	4,14 TL
TBp 2517	25	17	M 6	6	25	4,14 TL
TBp 2520	25	20	M 6	6	25	4,14 TL
TBp 2523	25	23	M 6	6	25	4,46 TL
TBp 2525	25	25	M 6	6	25	4,46 TL
TBp 2530	25	30	M 6	6	25	4,46 TL
TBp 3015	30	15	M 8	8	25	4,46 TL
TBp 3017	30	17	M 8	8	25	4,59 TL
TBp 3020	30	20	M 8	8	25	4,60 TL
TBp 3025	30	25	M 8	8	25	5,22 TL
TBp 3028	30	28	M 8	8	25	5,60 TL
TBp 3030	30	30	M 8	8	25	5,61 TL
TBp 3040	30	40	M 8	8	25	6,65 TL
TBp 3535	35	35	M 8	8	25	7,00 TL
TBp 4020	40	20	M 8	8	25	7,00 TL
TBp 4025	40	25	M 8	8	25	7,00 TL
TBp 4027	40	27	M 8	8	25	7,66 TL
TBp 4028	40	28	M 8	8	25	7,66 TL
TBp 4030	40	30	M 8	8	25	7,66 TL
TBp 4040	40	40	M 8	8	25	8,01 TL
TBp 4525	45	25	M 8	8	25	8,73 TL
TBp 4535	45	35	M 8	10	25	9,14 TL
TBp 5020	50	20	M 10	10	25	9,14 TL
TBp 5025	50	25	M 10	10	25	9,14 TL
TBp 5030	50	30	M 10	10	25	9,16 TL
TBp 5035	50	35	M 10	10	25	10,14 TL
TBp 5040	50	40	M 10	10	25	11,14 TL
TBp 5042	50	42	M 10	10	25	12,06 TL

TKCp CİVATALI KONİK TAKOZ/ Pullu



Ürün kodu	D	l1	d	h	Pkt	Fiyat
TKCp 110	110	50	12	27	10	31,45 TL
TKCp 160	160	75	12	28	10	50,31 TL

TMCp CİVATALI MAKARA TAKOZ/ Pullu



Ürün kodu	D	l1	d	h	Pkt	Fiyat
TMCp 80	80	60	8	27	25	37,73 TL

EMES Endüstriyel
Makina Ekipmanları

+90 216 304 06 83

+90 216 309 91 48

info@emesteker.com

www.emesteker.com



Orta Mah. 30 Ağustos Cad. No: 61
Tuzla - İstanbul / Türkiye