

Makaralı Zincirler  
BS Serisi (Avrupa Standardı) DIN-8187 - II Sıra

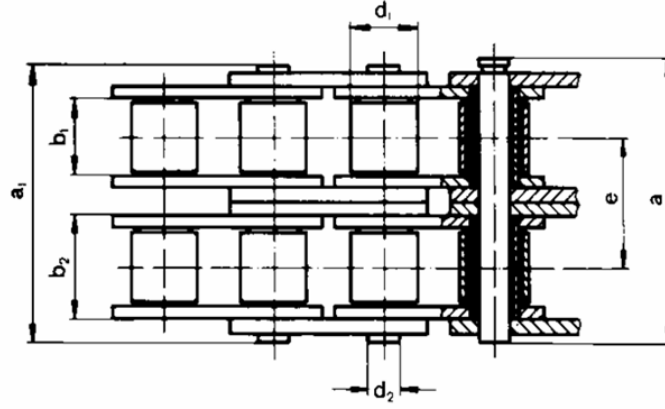

DIN ISO No:	p mm.	b1 mm. Min	b2 mm. Max.	d2 mm.	d1 mm. Max.	a1 mm. Max.	a mm. Max.	e mm.
05B-2	8,00	3,00	4,77	2,31	5,00	14,30	17,40	5,64
06B-2	9,525	5,72	8,53	3,28	6,35	23,30	27,10	10,24
08B-2	12,70	7,75	11,30	4,45	8,51	31,00	34,90	13,92
10B-2	15,875	9,65	13,28	5,08	10,16	36,20	40,30	16,59
12B-2	19,05	11,68	15,62	5,72	12,07	42,20	46,80	19,46
16B-2	25,40	17,02	25,45	8,28	15,88	68,00	73,40	31,88
20B-2	31,750	19,56	29,01	10,19	19,05	79,70	85,80	36,45
24B-2	38,10	25,40	37,92	14,63	25,40	101,80	108,40	48,36
28B-2	44,45	30,99	46,58	15,90	27,94	124,70	132,10	59,56
32B-2	50,80	30,99	45,57	17,81	29,21	126,00	133,90	58,55
40B-2	63,50	38,10	55,75	22,89	39,37	154,90	165,10	72,29
48B-2	76,20	45,72	70,56	29,24	48,26	190,40	200,90	91,21
56B-2	88,90	53,34	81,33	34,32	53,98	223,80	232,30	106,60
64B-2	101,60	60,96	92,02	39,40	63,50	251,40	260,00	119,89
72B-2	114,30	68,58	103,82	44,48	72,39	285,00	293,50	136,27