

Makaralı Zincirler
BS Serisi (Avrupa Standardı) DIN-8187 - I Sıra

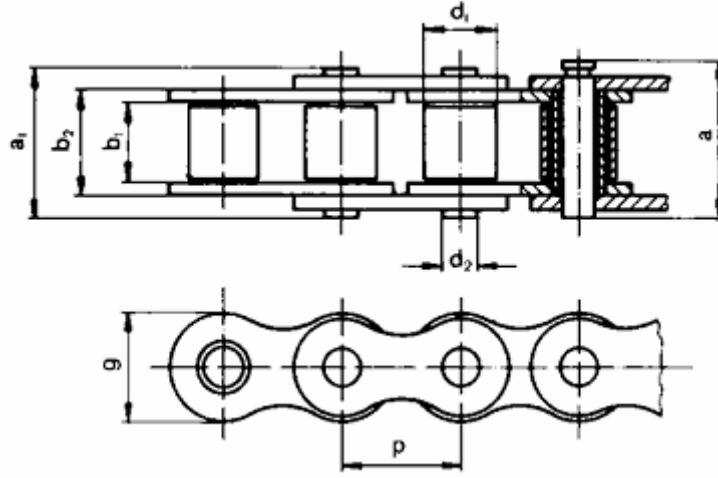

DIN ISO No:	p mm.	b1 mm. Min	b2 mm. Max.	d2 mm.	d1 mm. Max.	a1 mm. Max.	a mm. Max.
03B-1	5,00	2,50	3,70	1,49	3,20	6,50	7,40
04B-1	6,00	2,80	4,10	1,85	4,00	7,40	10,30
05B-1	8,00	3,00	4,77	2,31	5,00	8,60	11,70
06B-1	9,525	5,72	8,53	3,28	6,35	13,50	16,80
081-1	12,70	3,30	5,80	3,66	7,75	10,20	11,70
083-1	12,70	4,88	7,97	3,68	7,75	13,20	14,10
084-1	12,70	6,40	9,65	3,97	7,75	15,00	16,00
08B-1	12,70	7,75	11,30	4,45	8,51	17,00	20,90
10B-1	15,875	9,65	13,28	5,08	10,16	19,60	23,70
12B-1	19,05	11,68	15,62	5,72	12,07	22,70	27,30
16B-1	25,40	17,02	25,42	8,28	15,88	36,10	41,50
20B-1	31,75	19,56	29,01	10,19	19,05	43,20	49,30
24B-1	38,10	25,40	37,92	14,63	25,40	53,40	60,00
28B-1	44,45	30,99	46,58	15,90	27,94	65,10	72,50
32B-1	50,80	30,99	45,57	17,81	29,21	67,40	75,30
40B-1	63,50	38,10	55,75	22,89	39,37	82,60	92,80
48B-1	76,20	45,72	70,56	29,24	48,26	99,10	109,60
56B-1	88,90	53,34	81,33	34,32	53,98	117,00	126,60
64B-1	101,60	60,96	92,02	39,40	63,50	131,40	140,00
72B-1	114,30	68,58	103,81	44,48	72,39	148,70	157,20